

DOCUMENTO Nº2: PLANOS

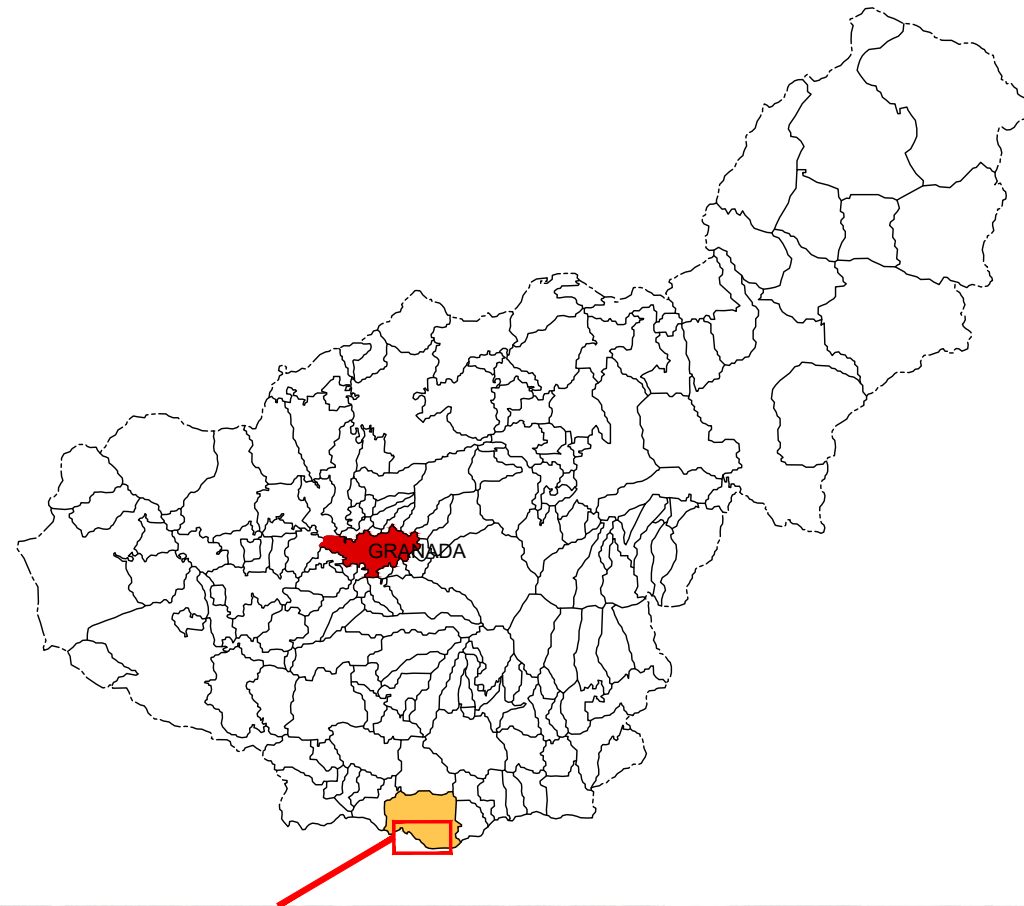

Escala = 1:10.000





TÍTULO DEL PROYECTO:
**CONSTRUCCIÓN DE GLORIETA EN CARRETERA N-340,
 ACCESO OESTE MOTRIL, P.K. 330+800.
 PROVINCIA DE GRANADA**



AUTOR DEL PROYECTO:
**JUAN MARTÍN FERNÁNDEZ
 COLEGIADO Nº: 13.958**

DIRECTOR DEL CONTRATO:
DARÍO RODRÍGUEZ PEDROSA

FECHA:
OCTUBRE 2020

ESCALA:
1:1.000

DESIGNACIÓN DEL PLANO:
TOPOGRÁFICO

Nº PLANO:
2
 Hoja:
1 de 1



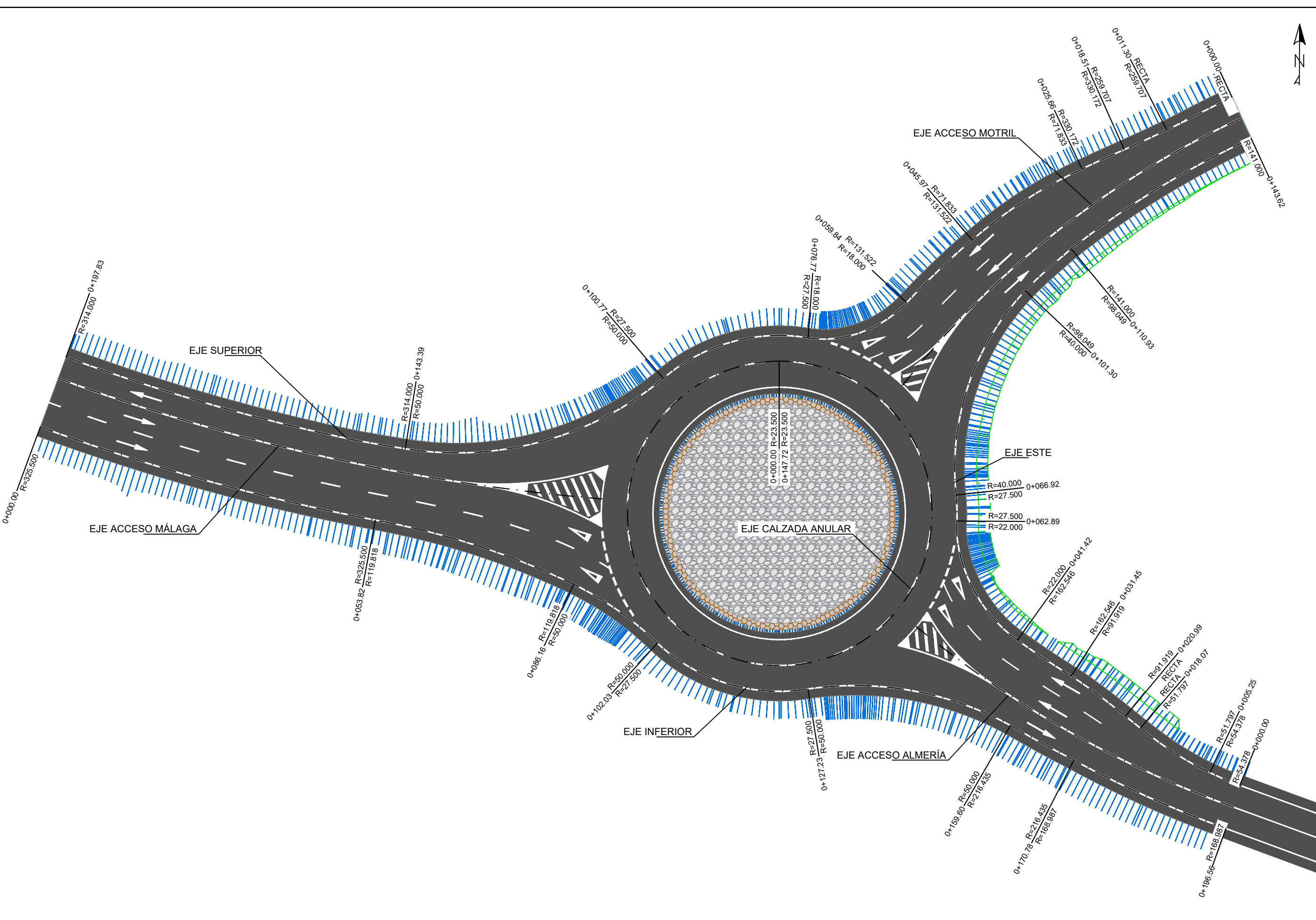



TABLA DE PUNTOS		
Nº DE PUNTO	COORD. ESTE	COORD. NORTE
1	451600.63	4066175.48
2	451490.39	4066199.65
3	451486.41	4066188.86
4	451669.69	4066126.79
5	451672.06	4066133.38
6	451673.59	4066233.42
7	451670.64	4066239.77
8	451574.14	4066182.86
9	451573.21	4066173.43
10	451619.05	4066155.06
11	451623.50	4066160.21
12	451621.94	4066192.88
13	451618.02	4066196.79







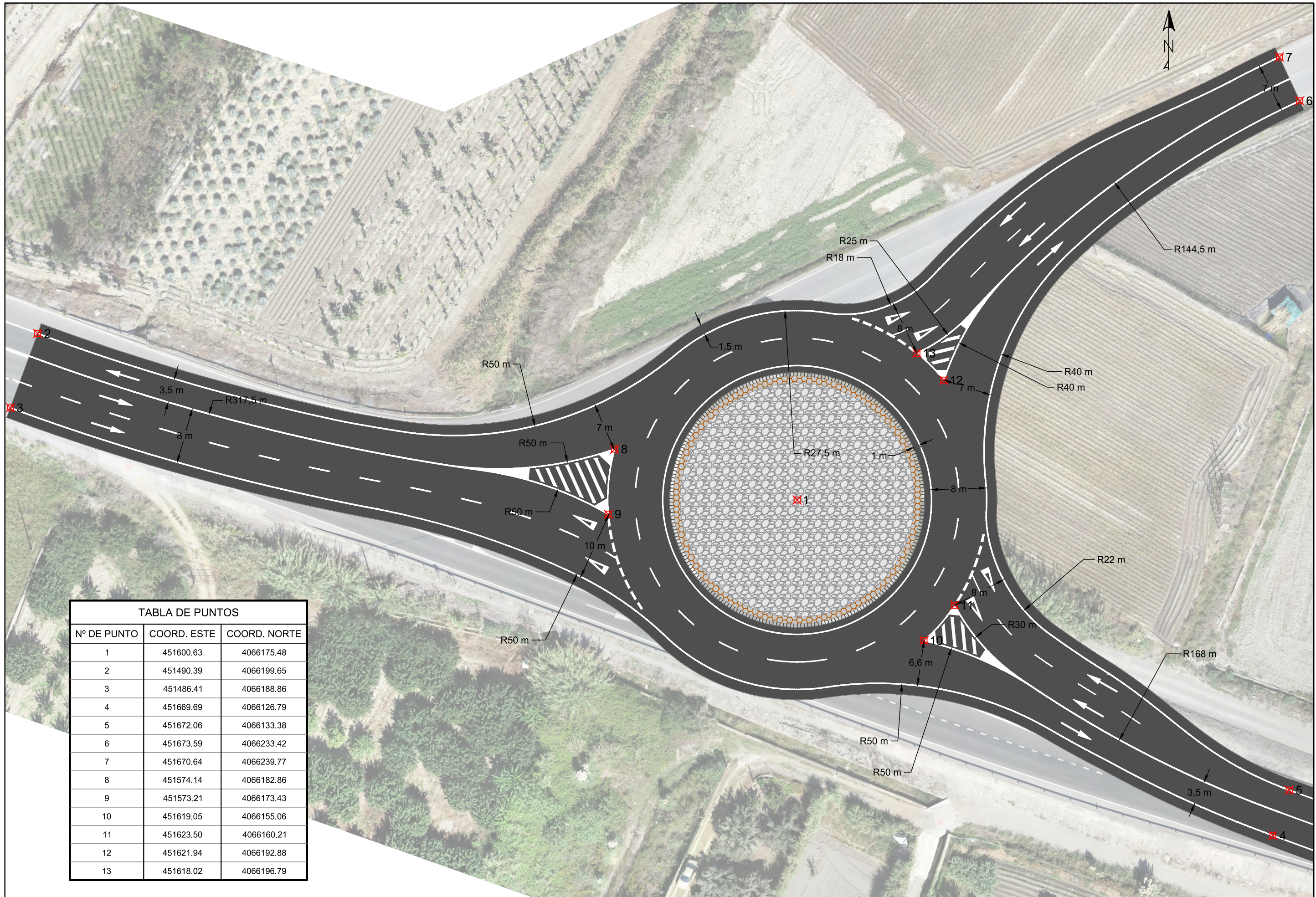
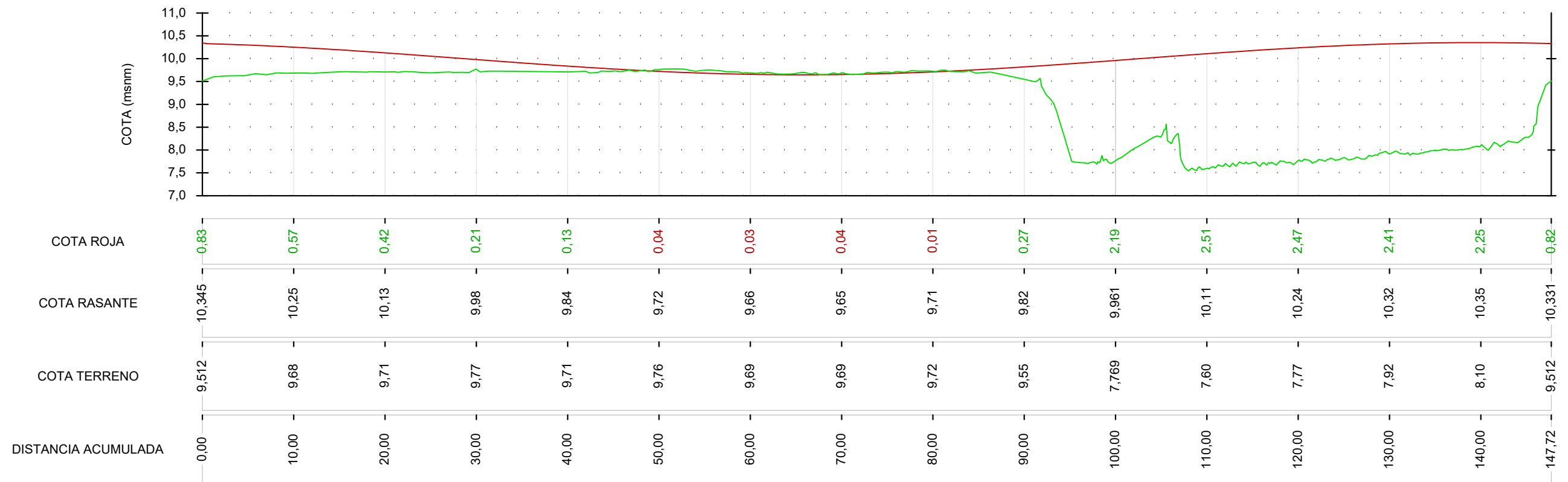
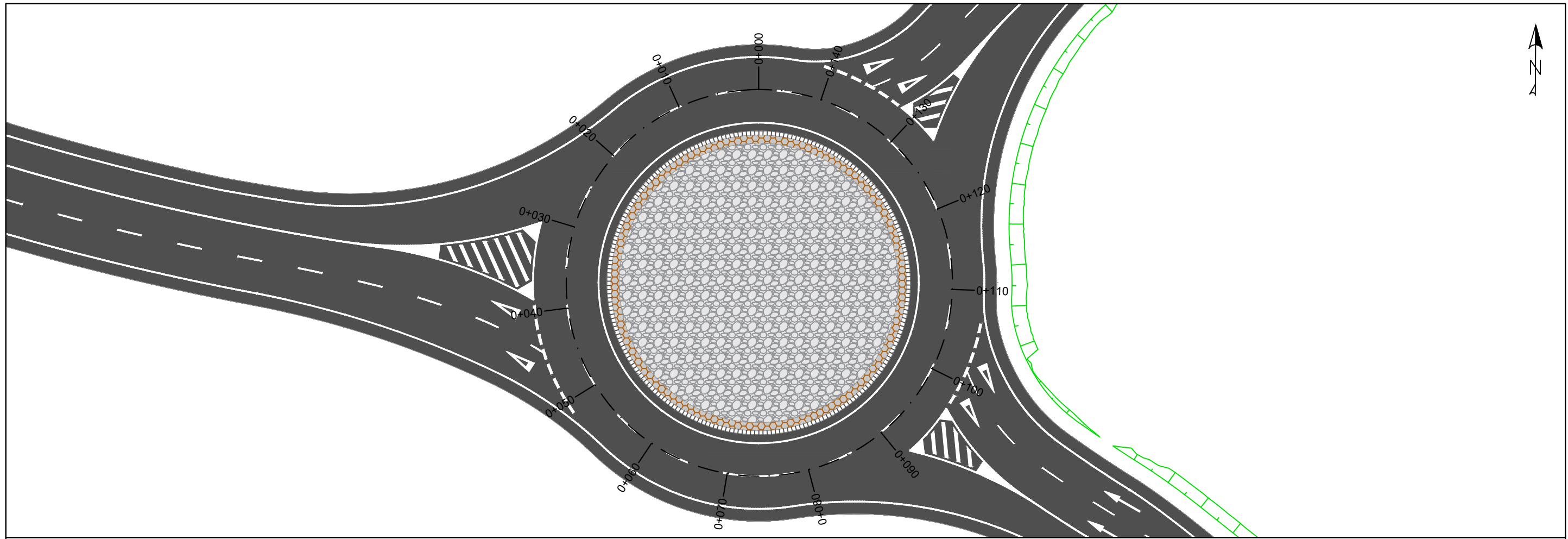
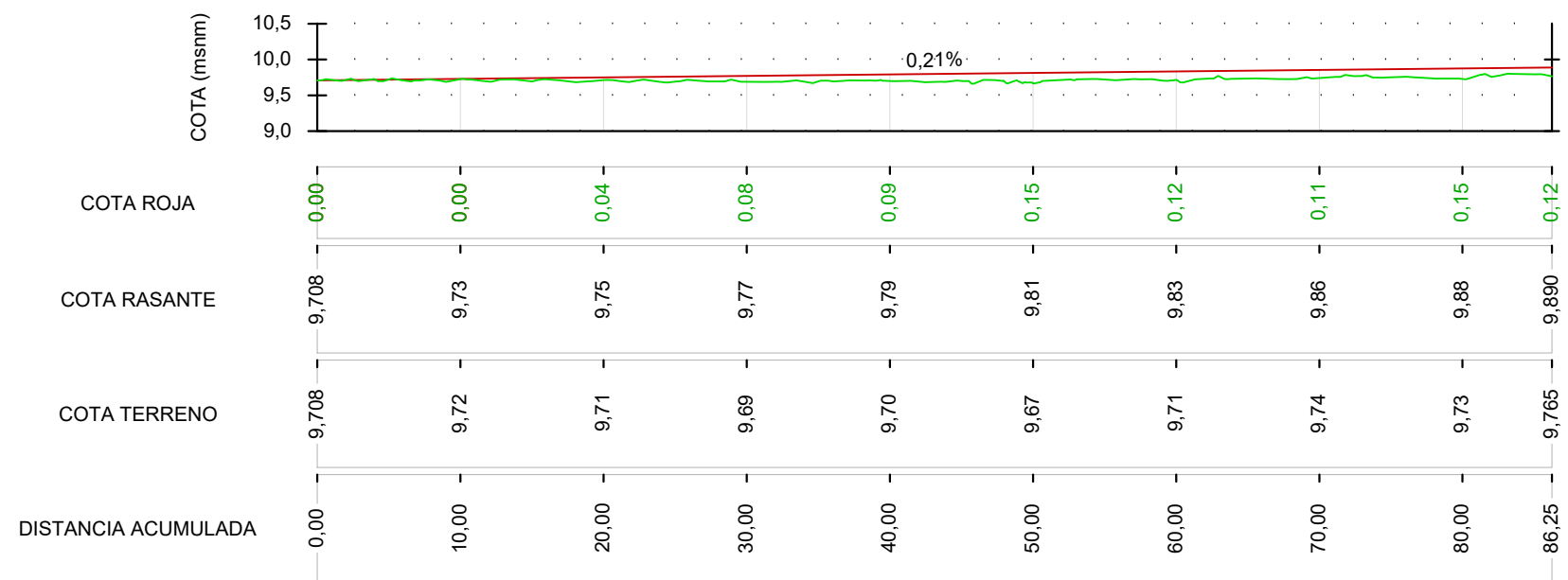
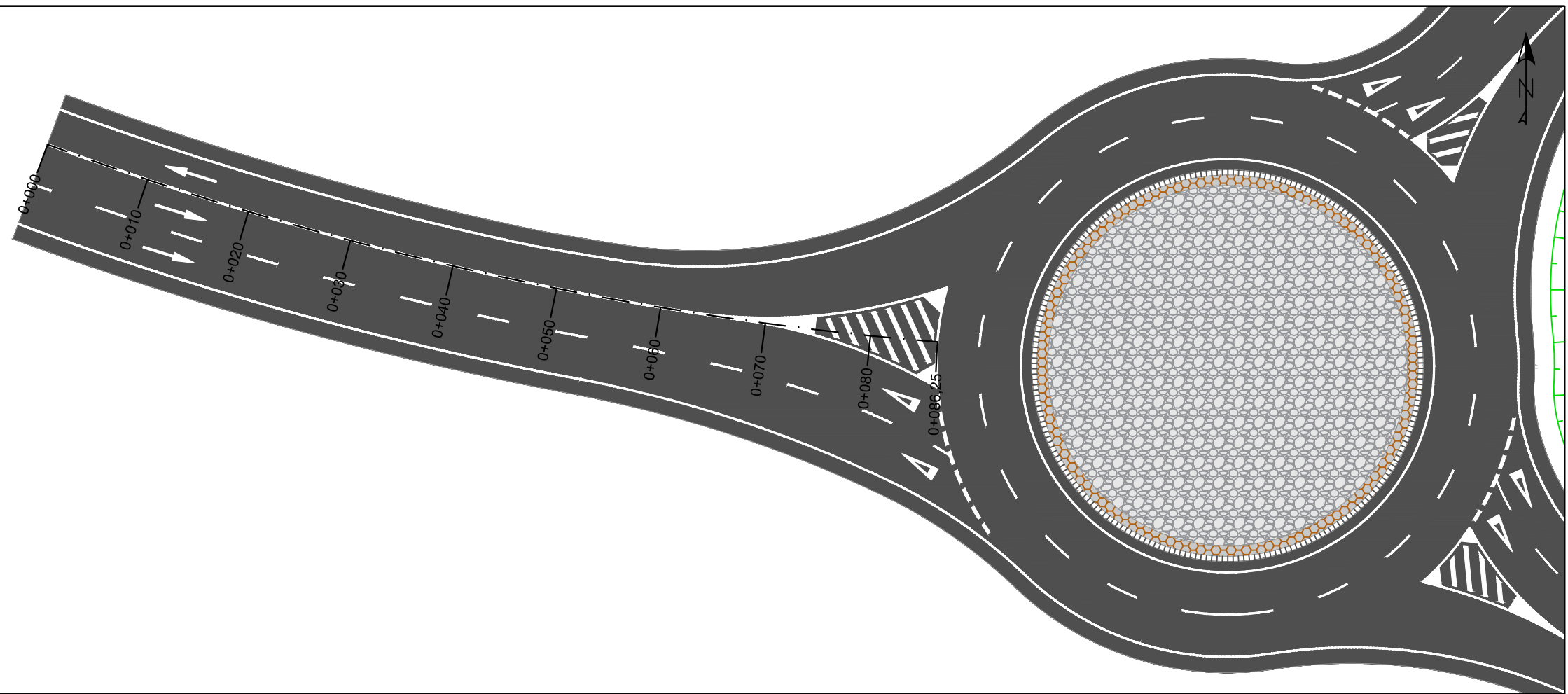
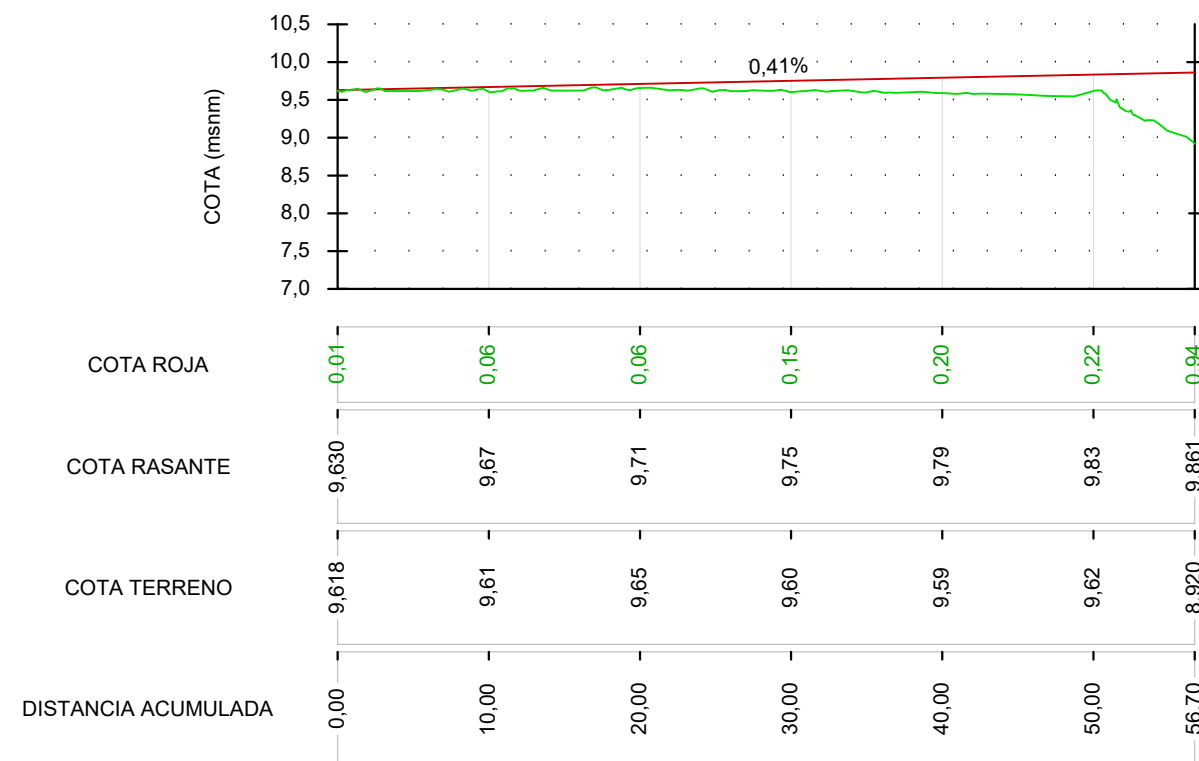
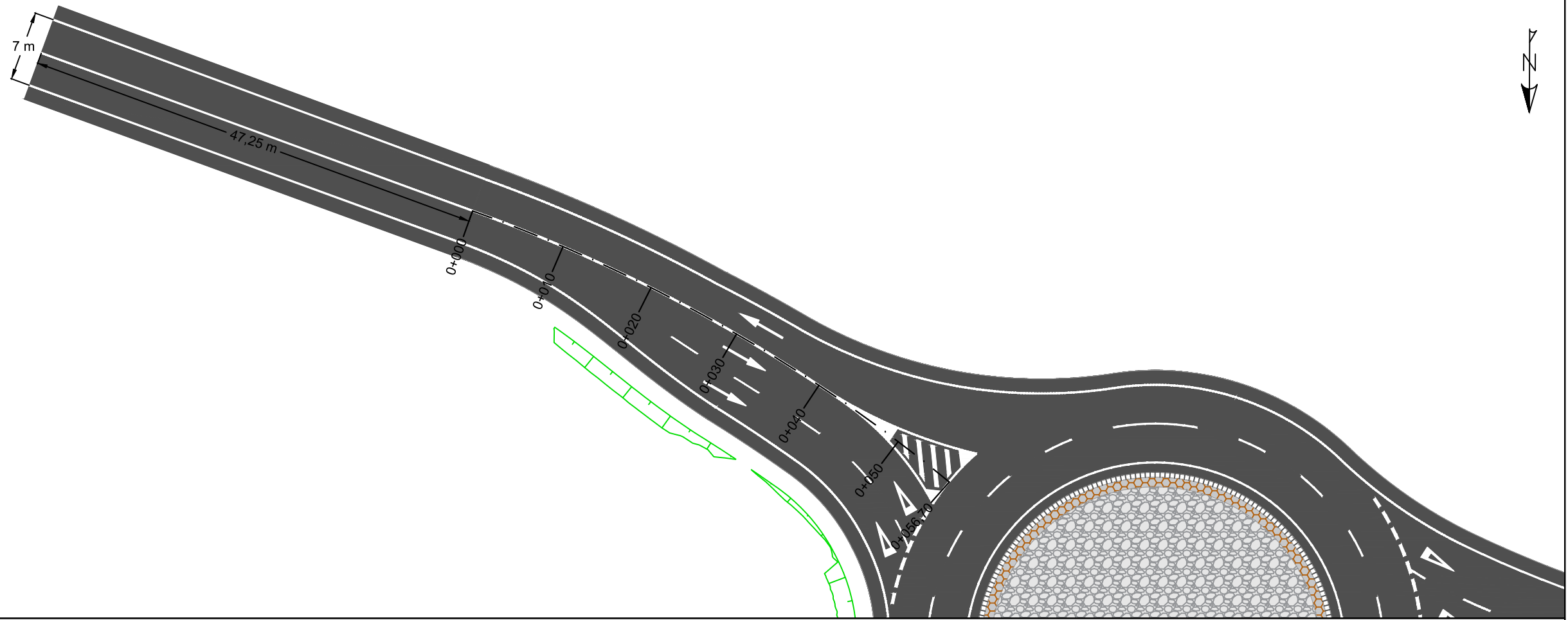
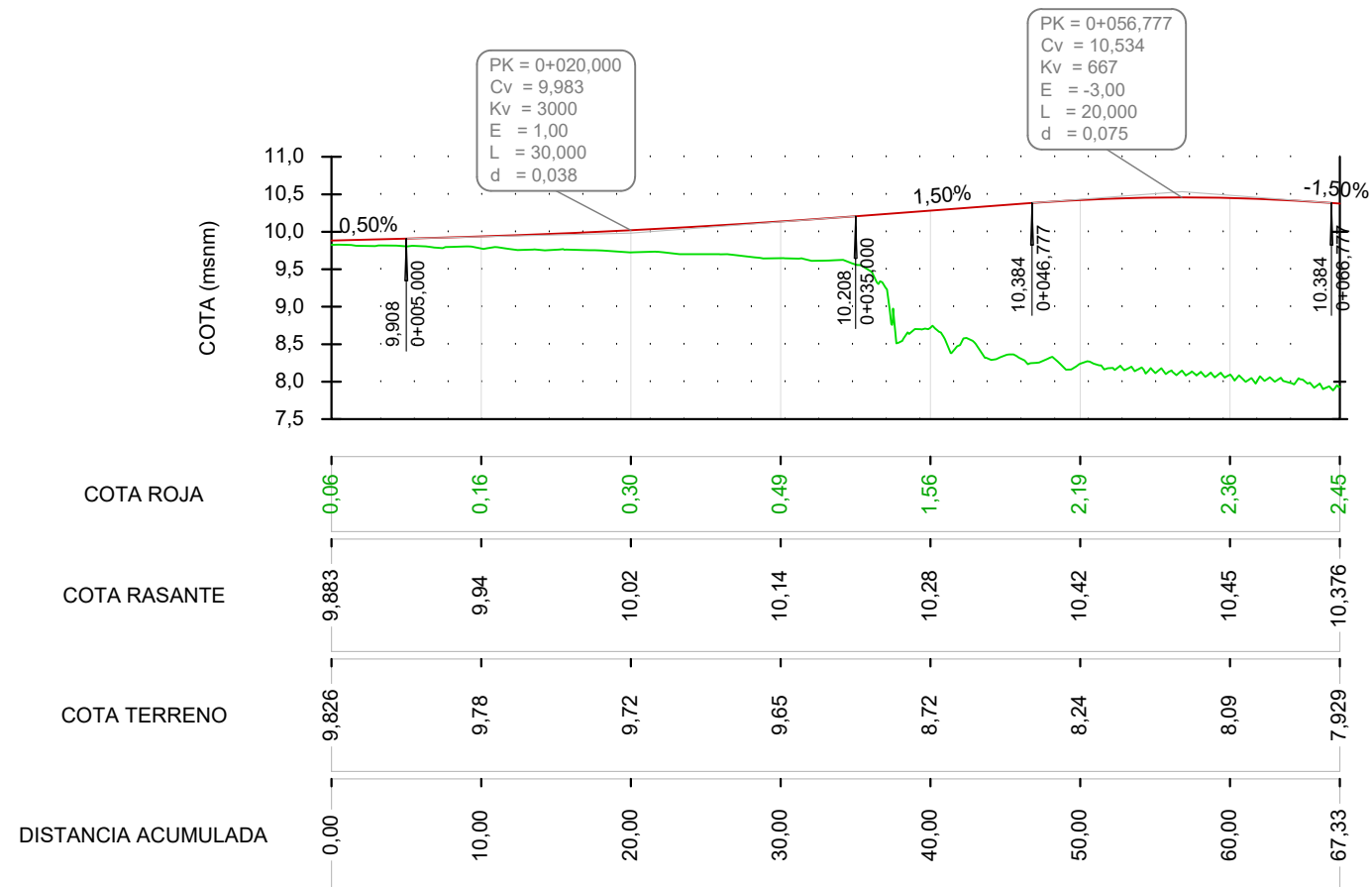
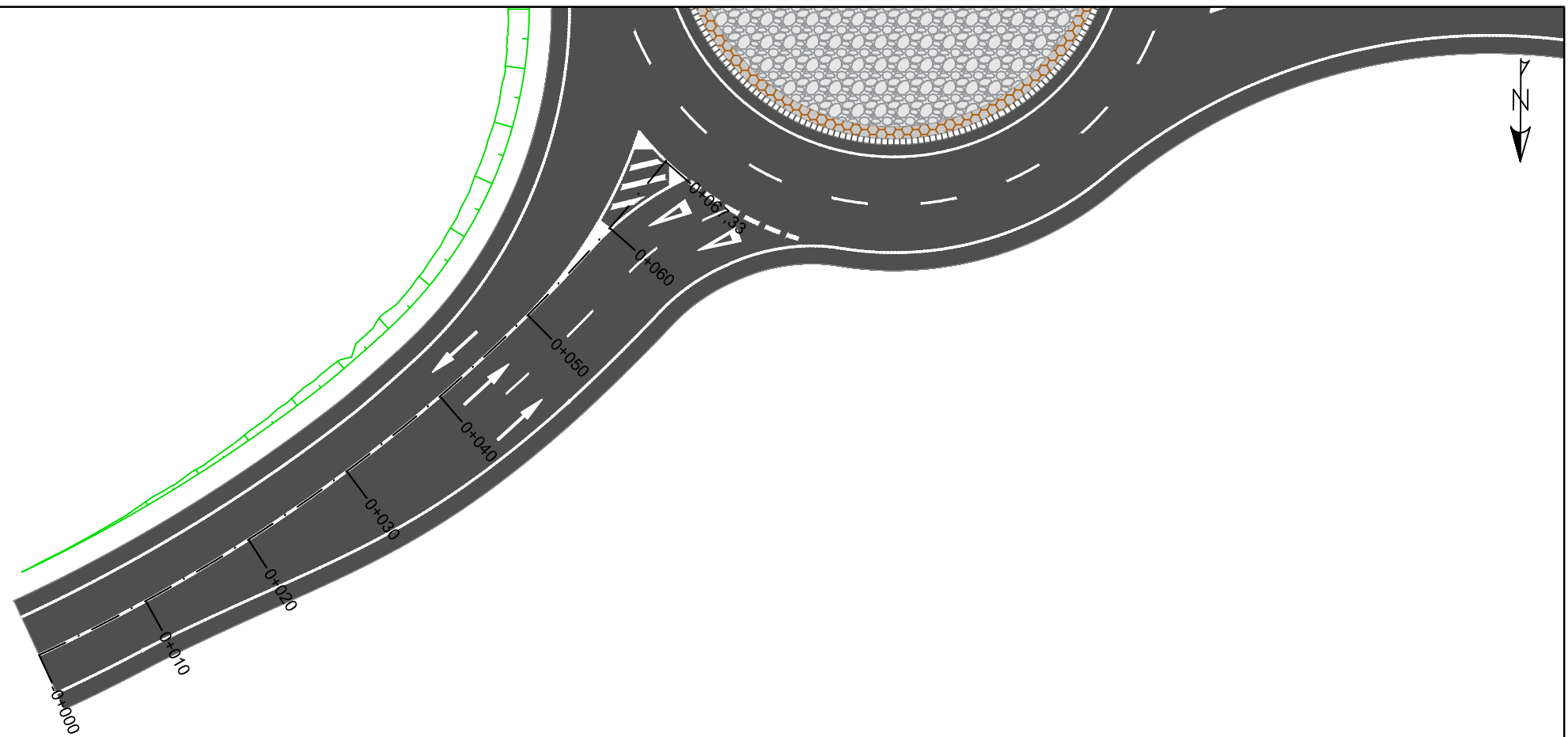

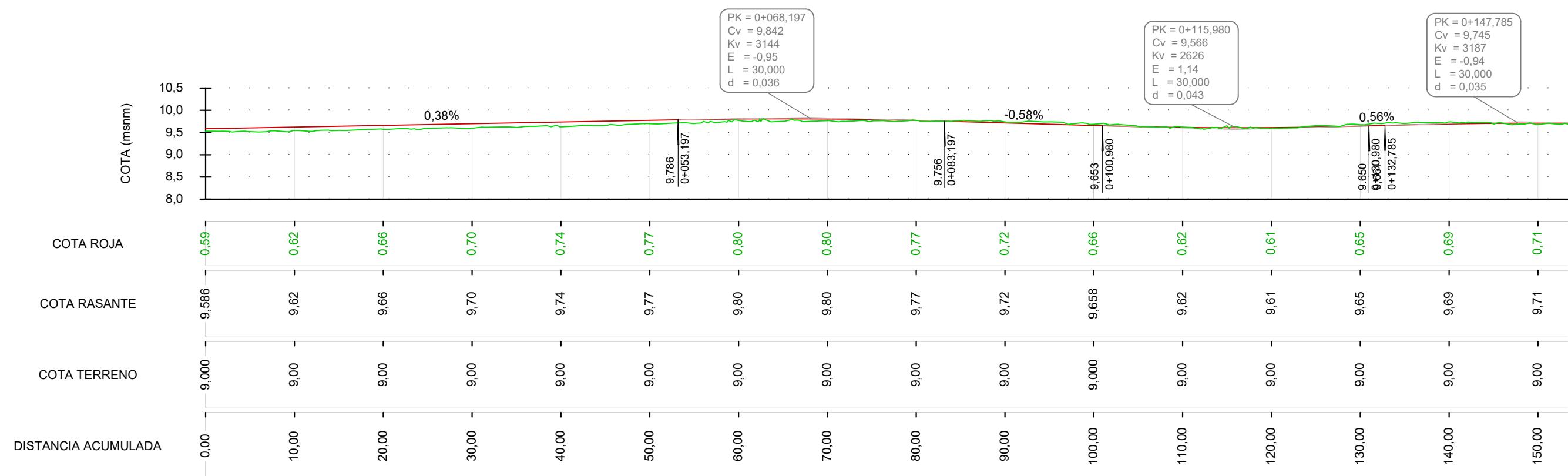
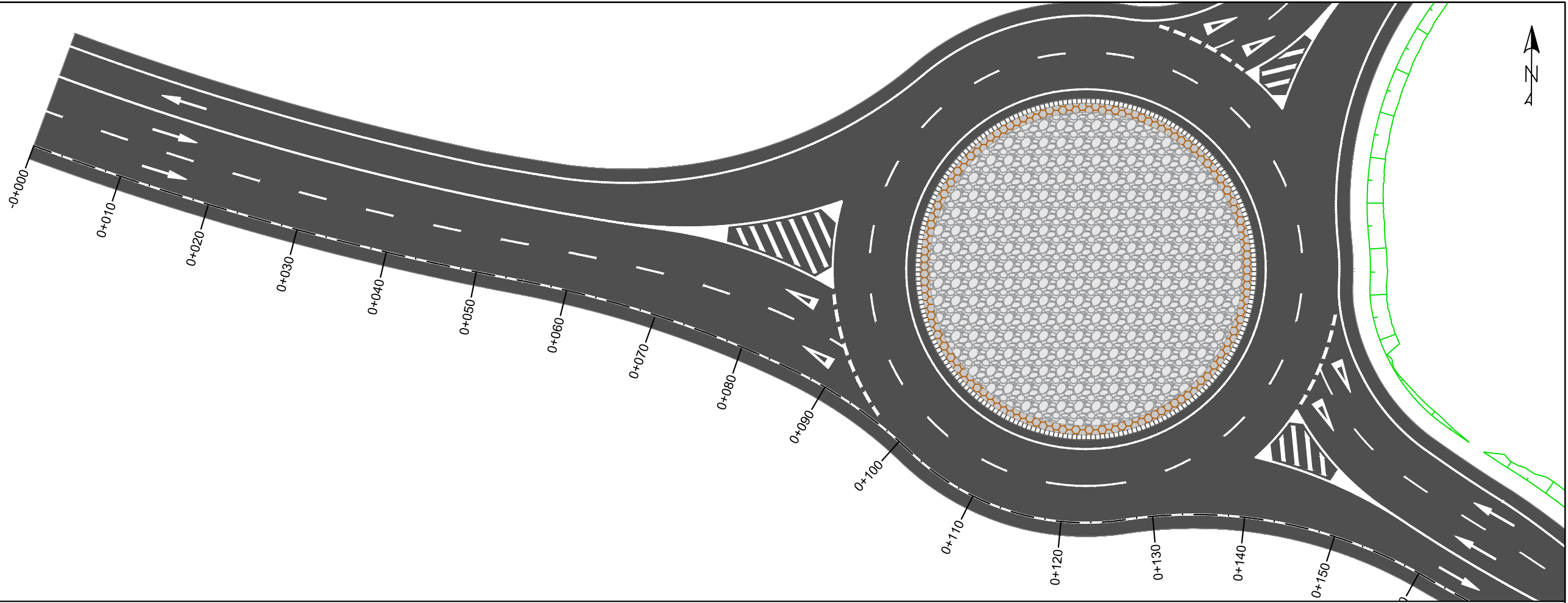

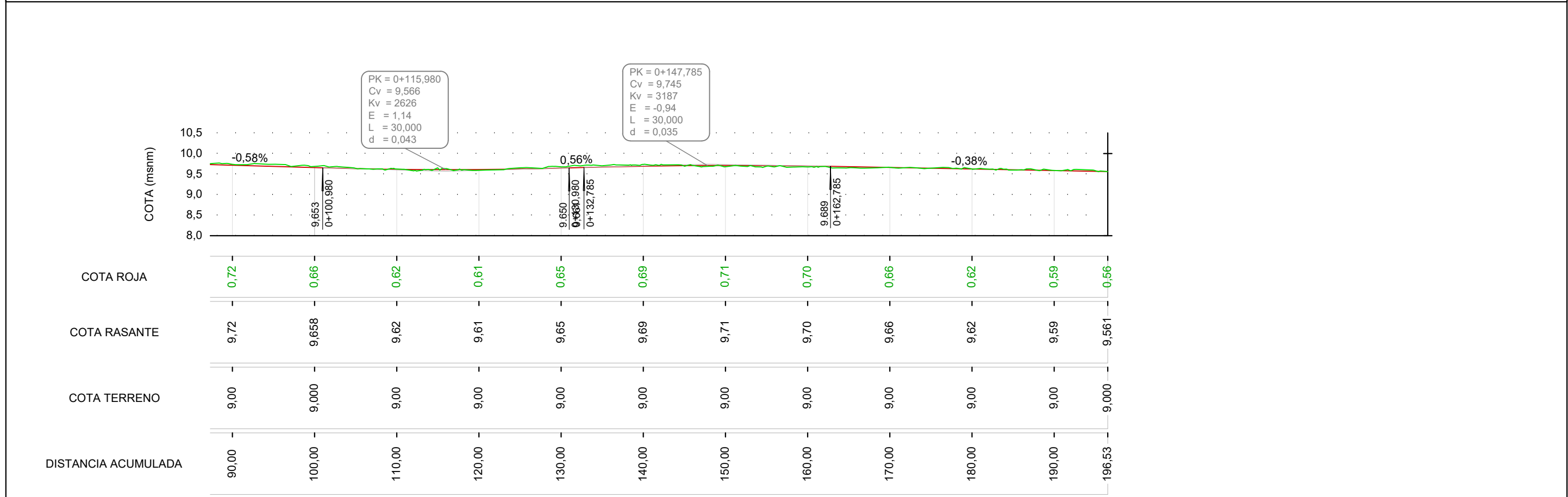
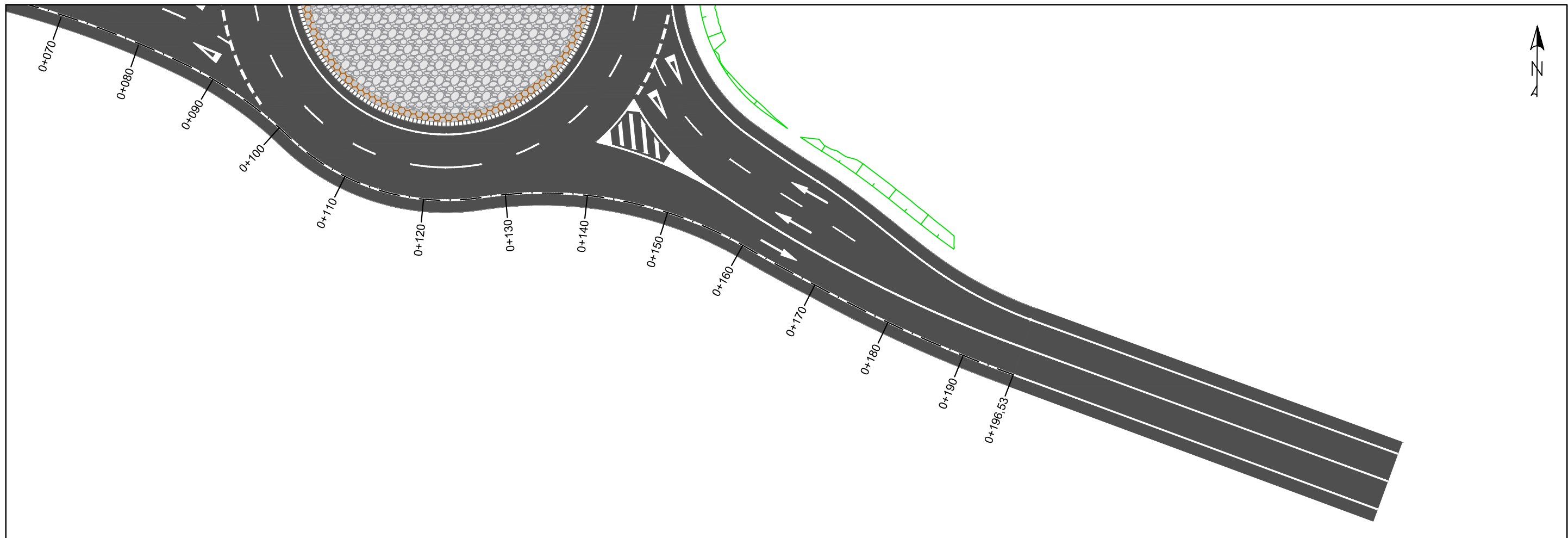

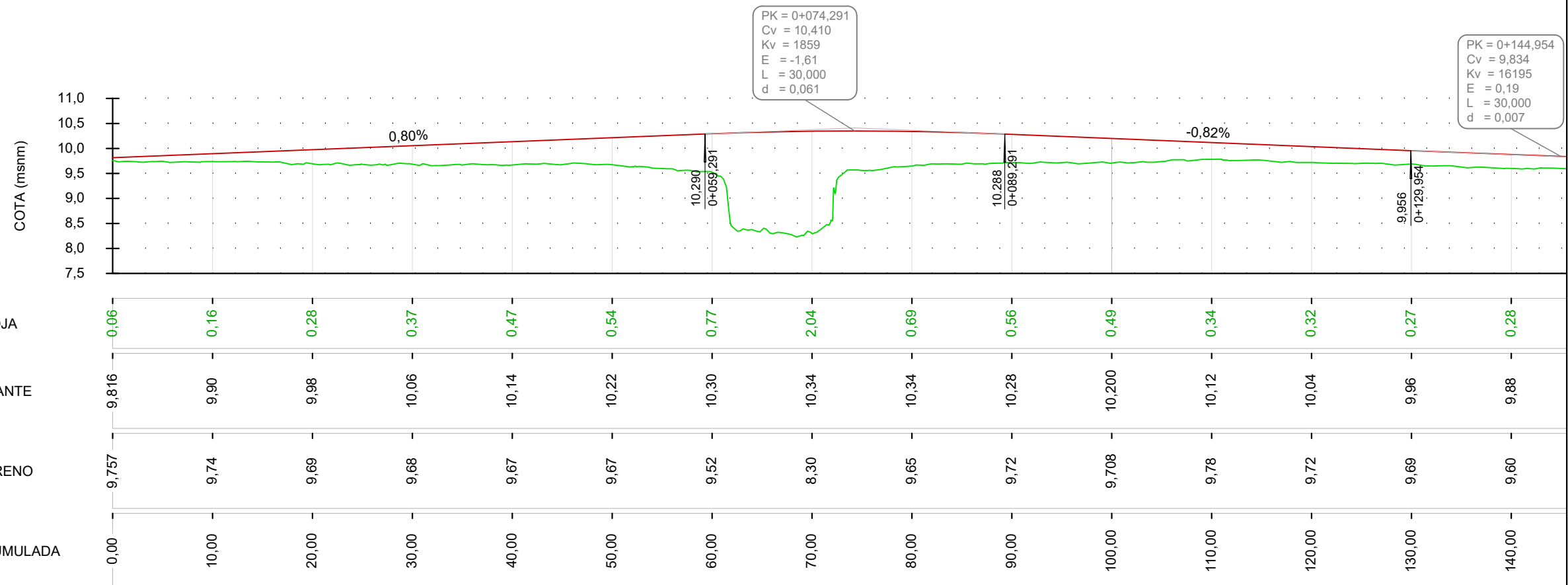
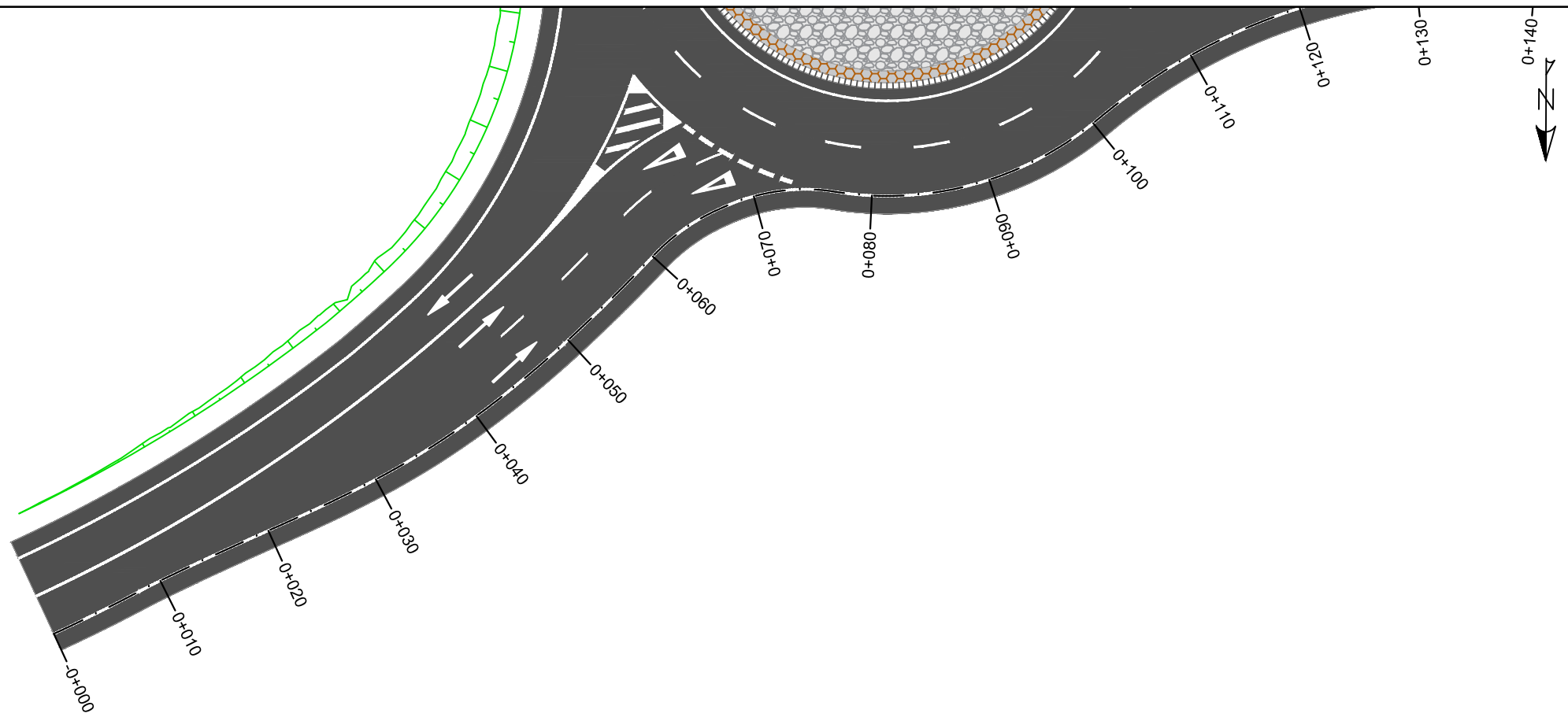

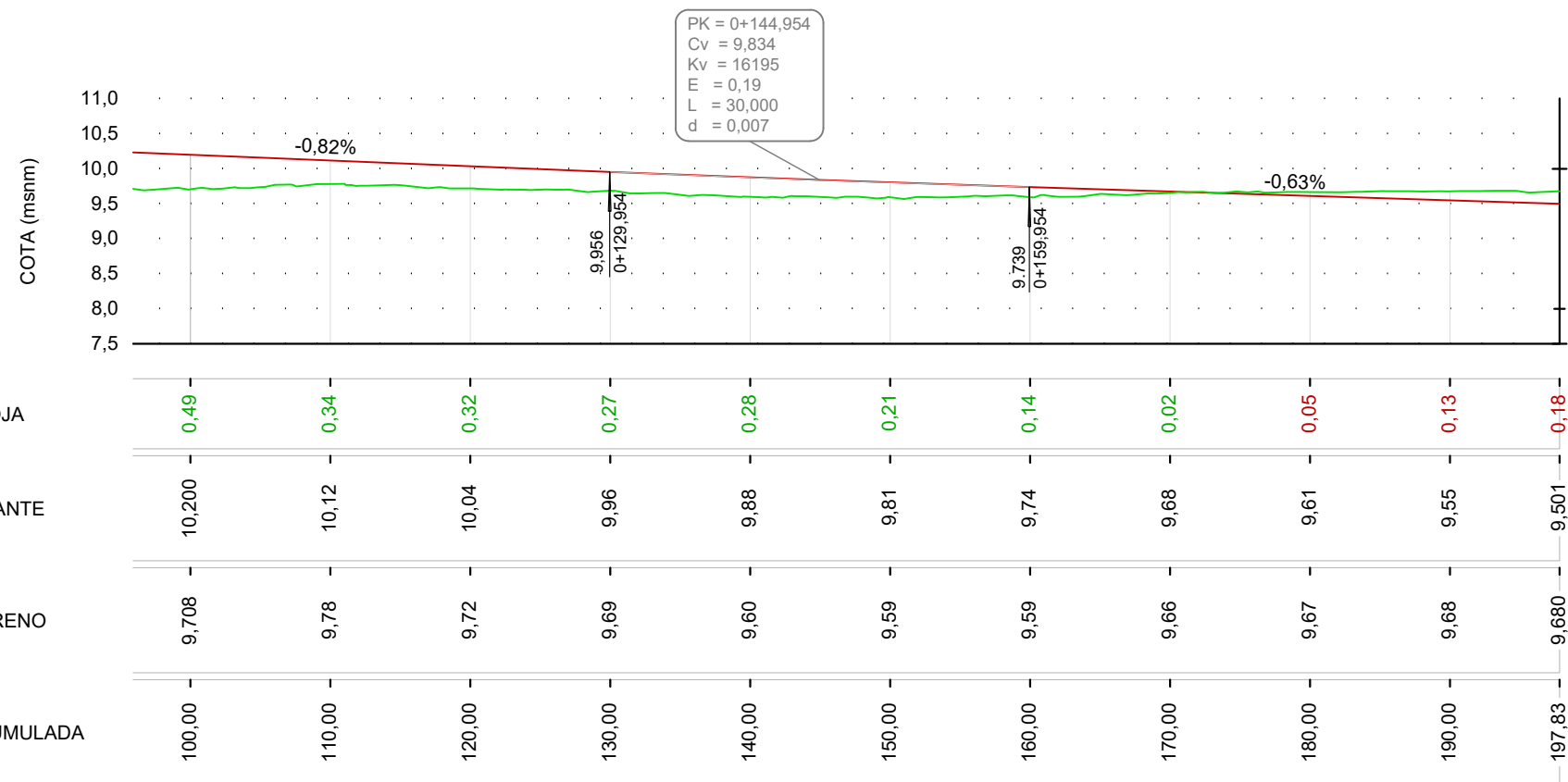
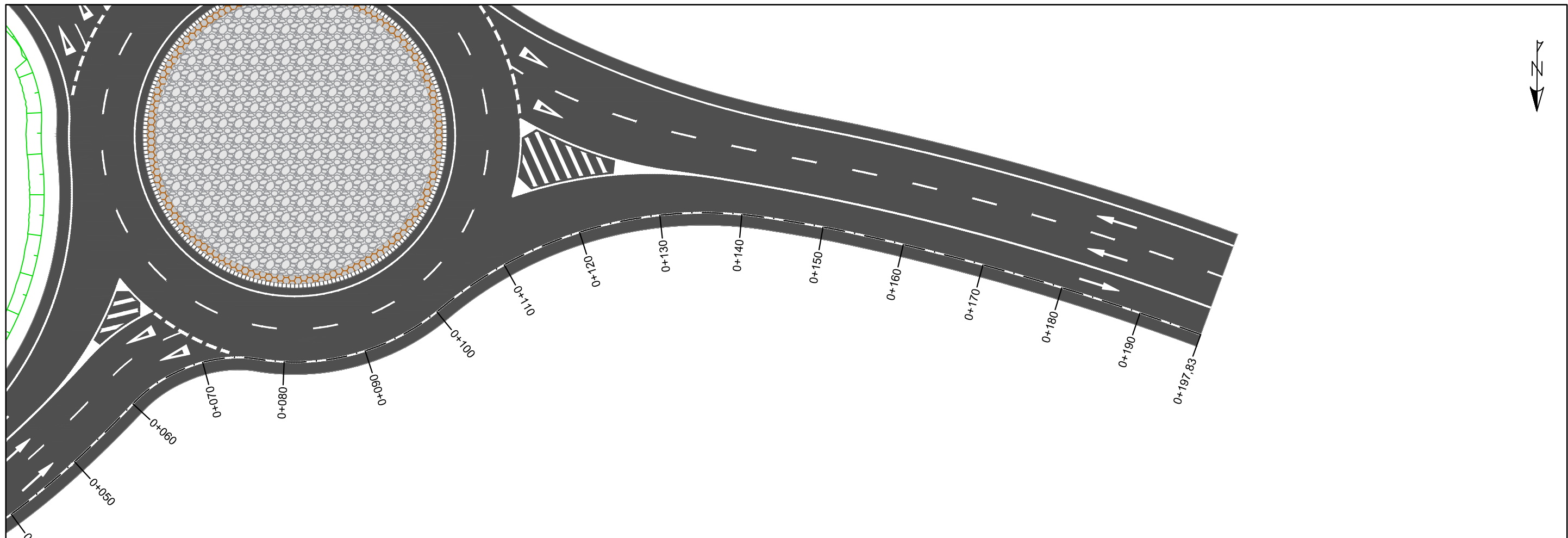

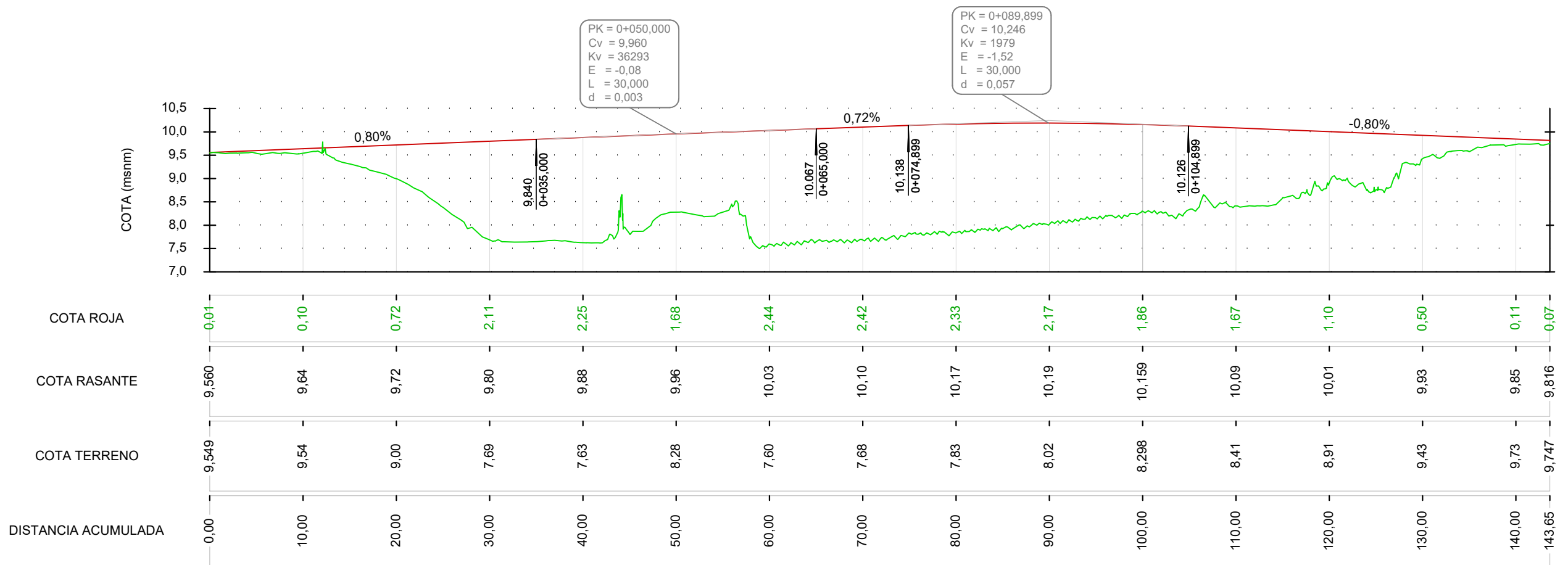
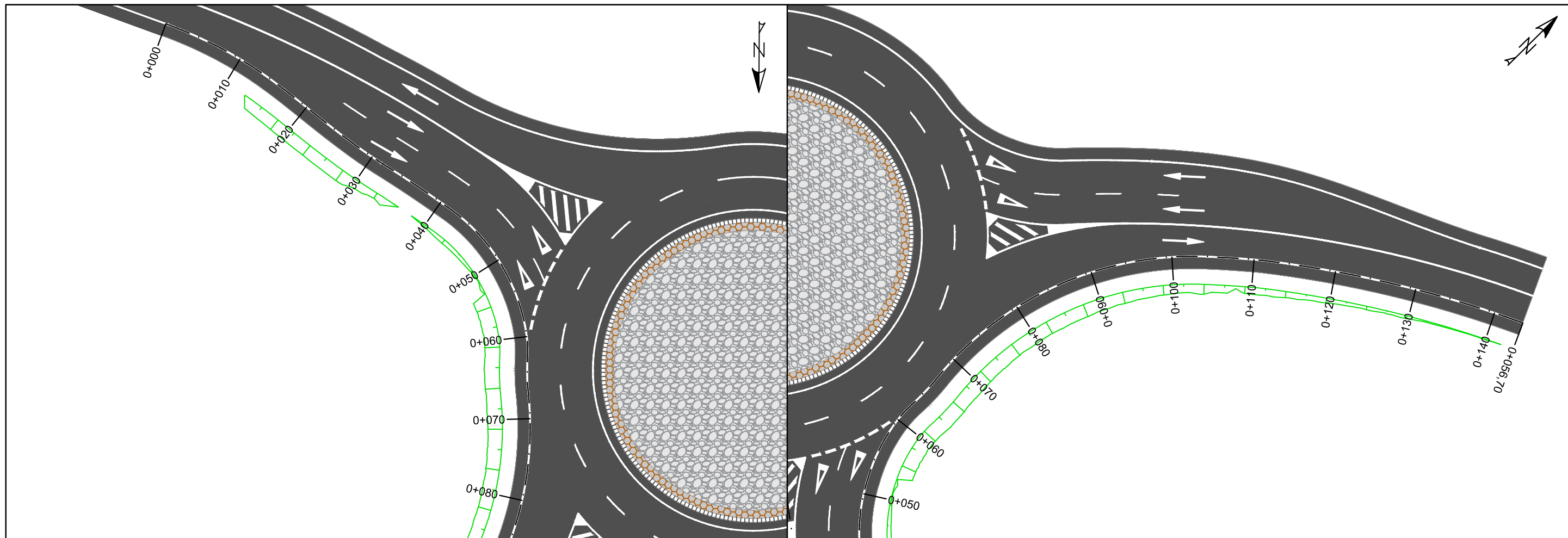

SECCIÓN TIPO SUPERFICIE DE RIEGO

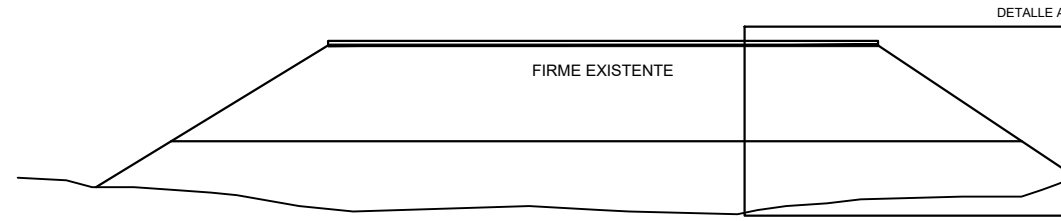

DETALLE A

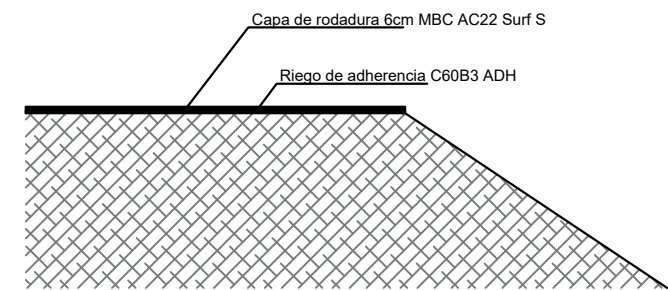

SECCIÓN TIPO SUPERFICIE FRESADO 8 CM

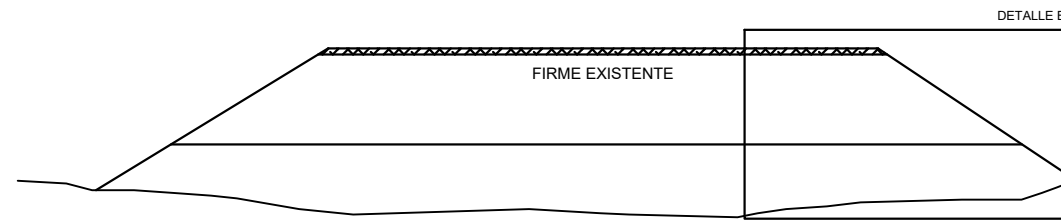

DETALLE B

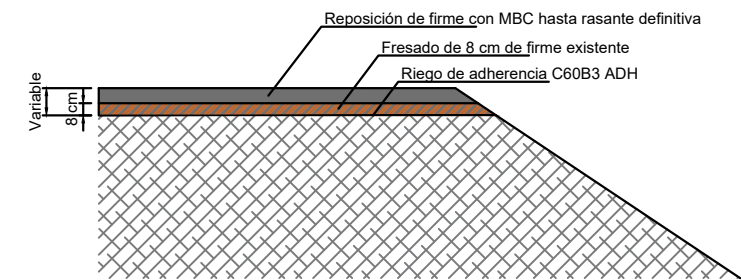

SECCIÓN TIPO SUPERFICIE ESCARIFICADO FIRME

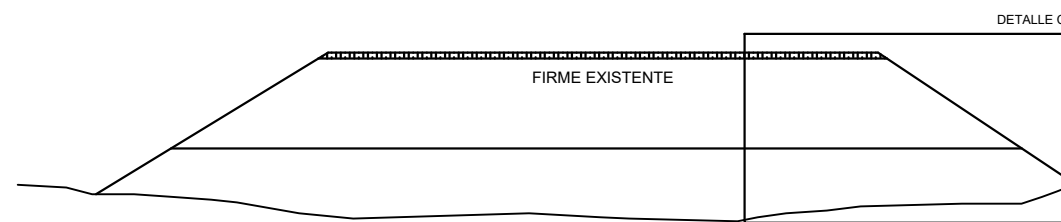

DETALLE B

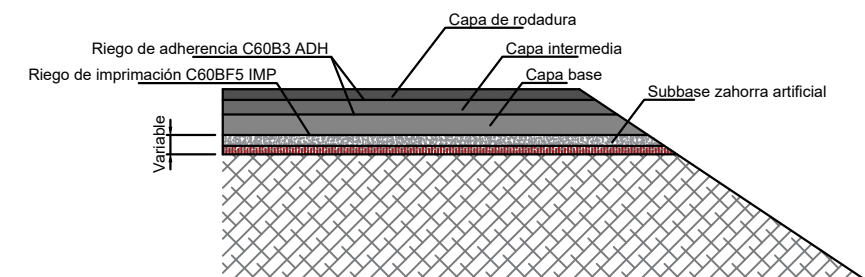

SECCIÓN TIPO GLORIETA
COTAS EN M

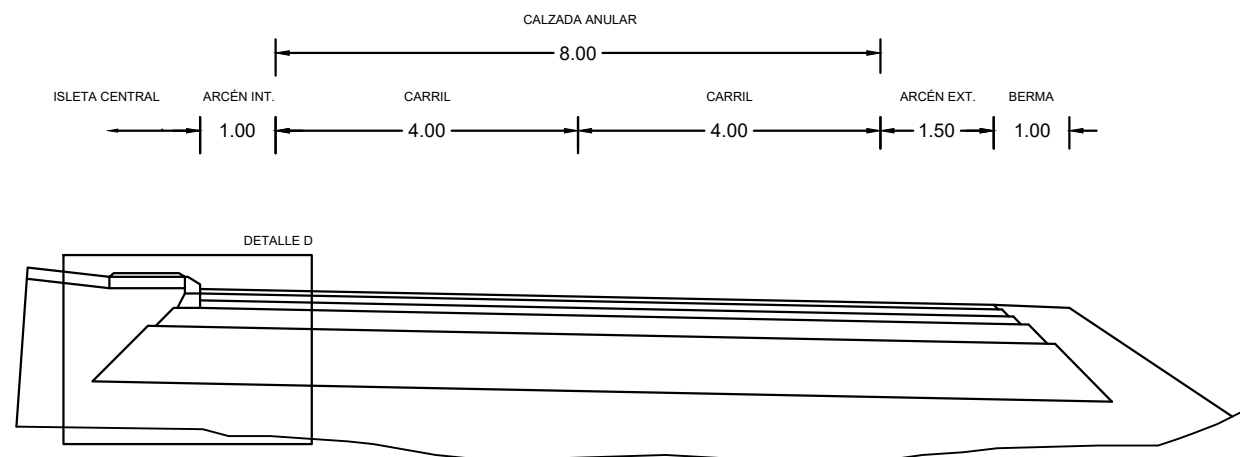

DETALLE D

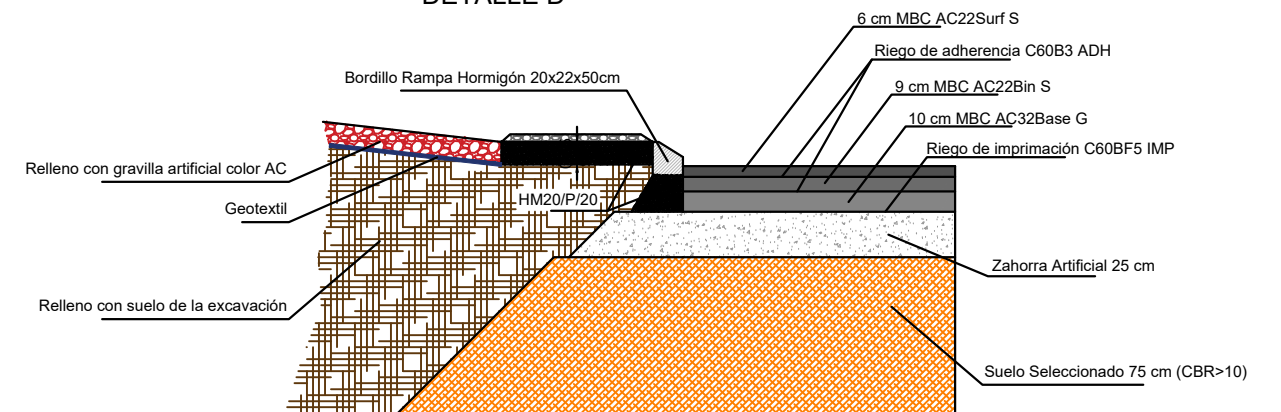

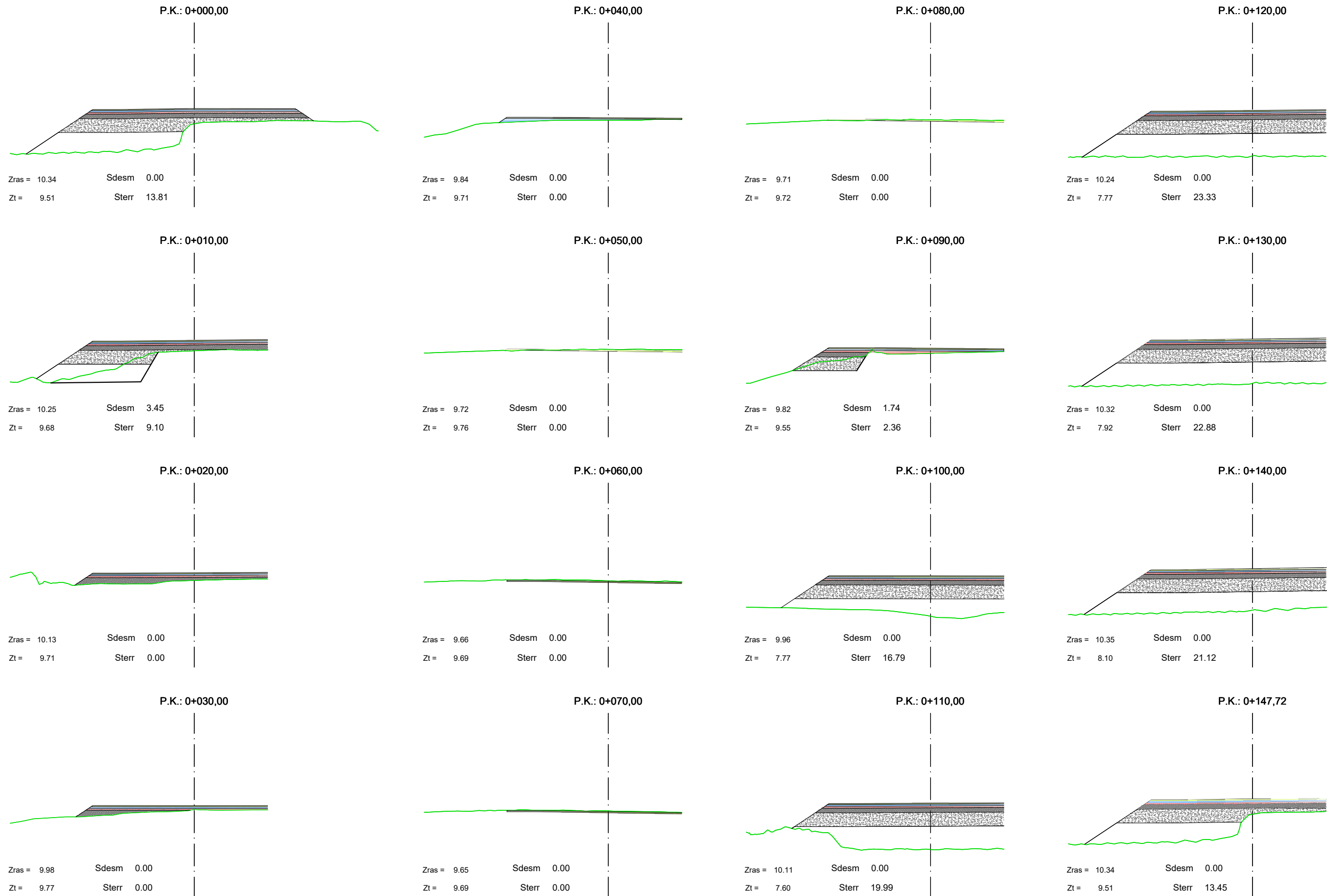

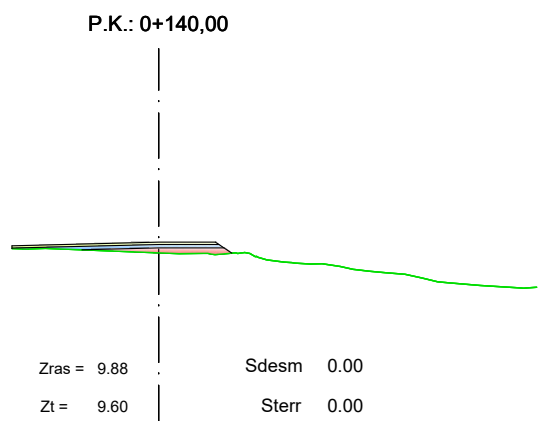
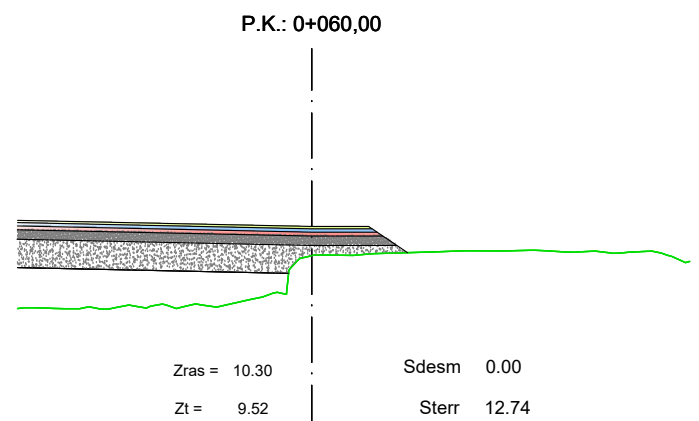
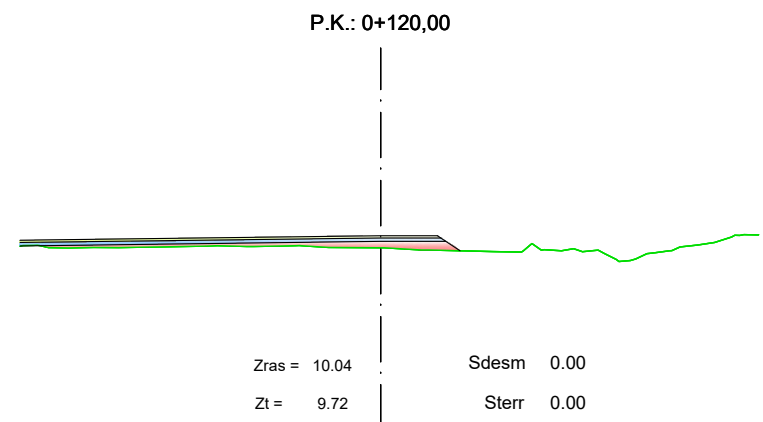
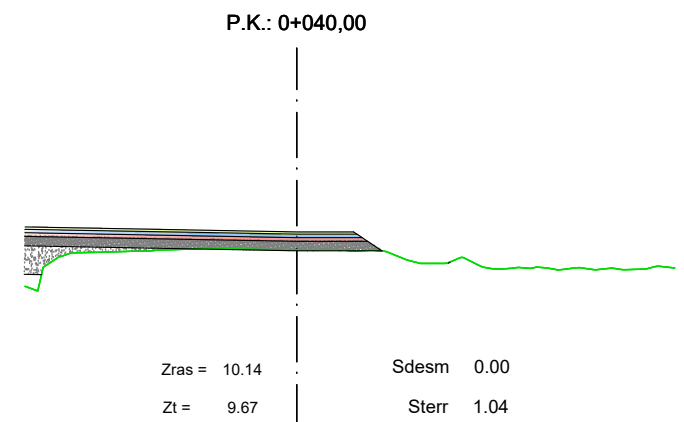
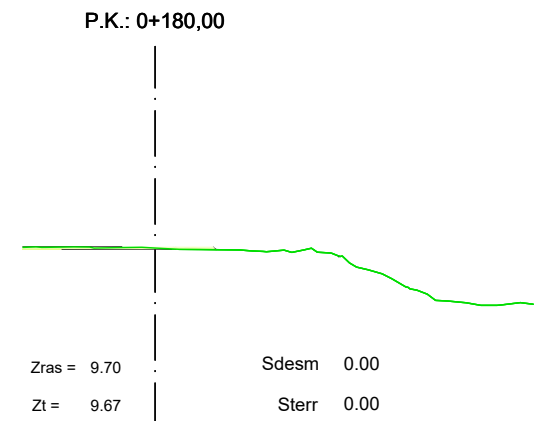
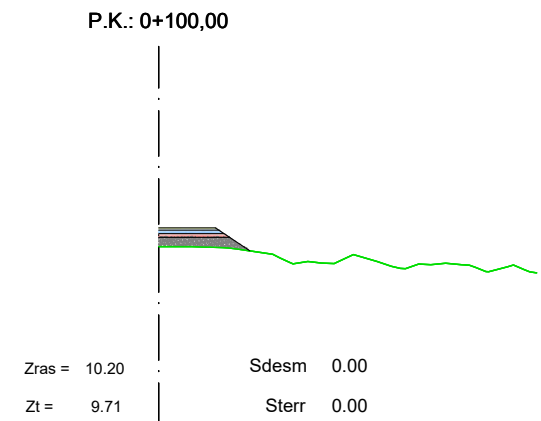
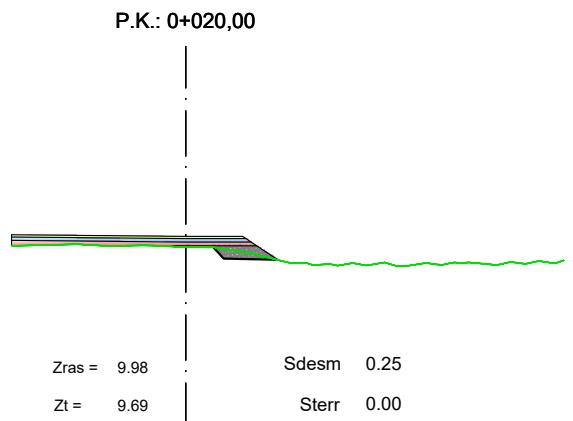
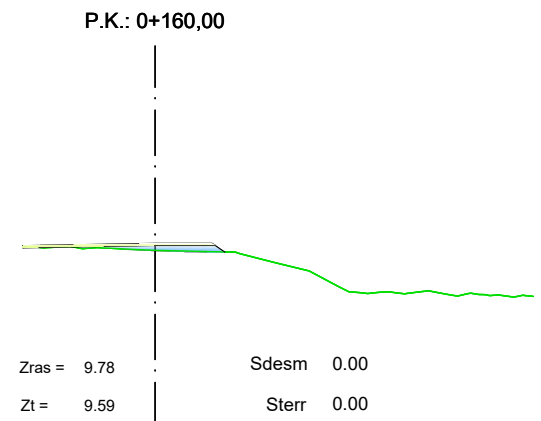
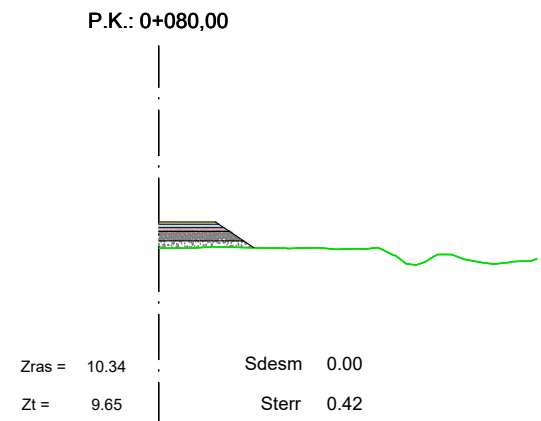
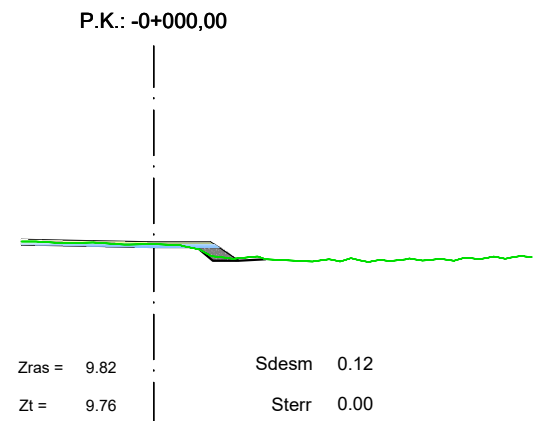

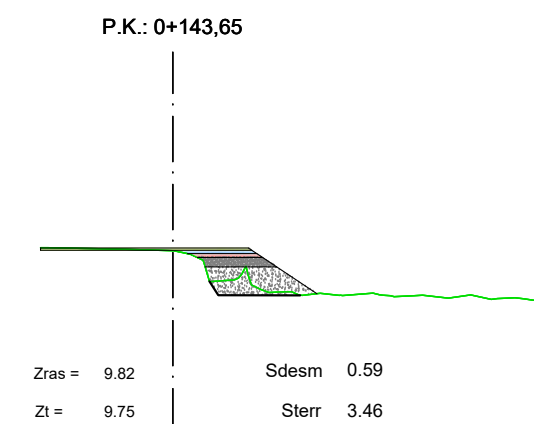
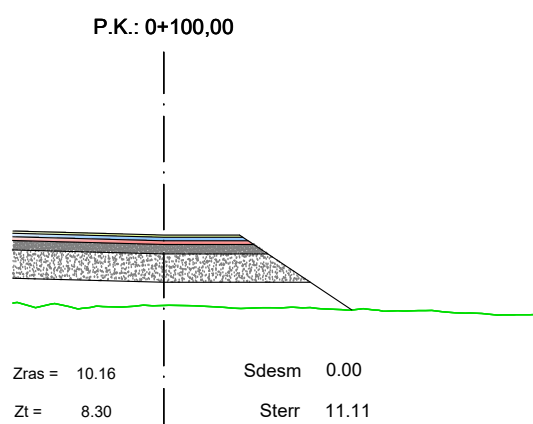
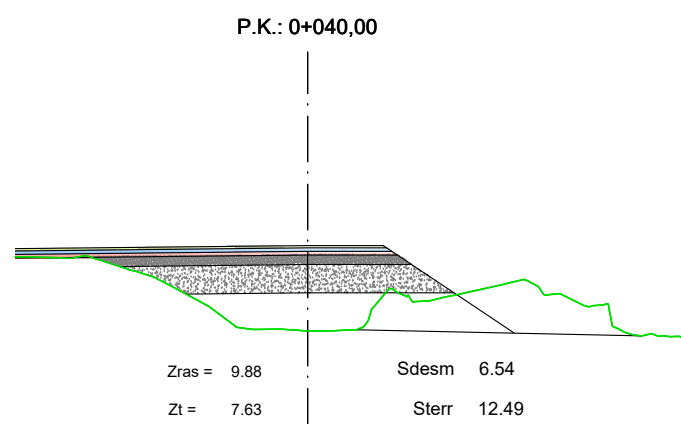
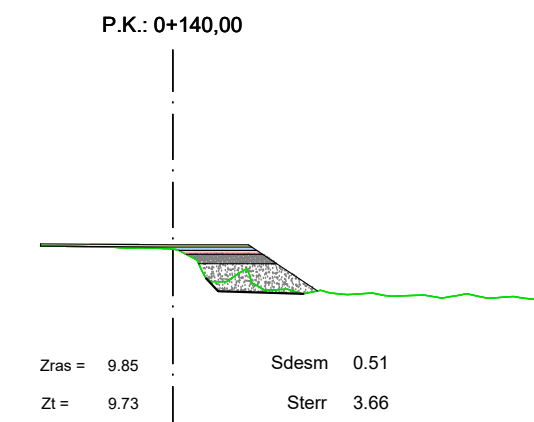
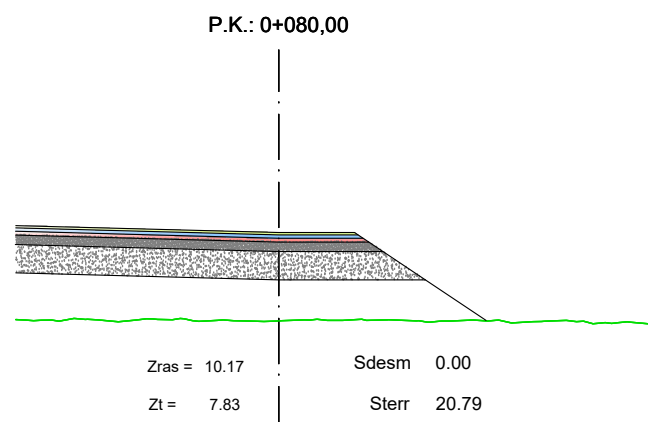
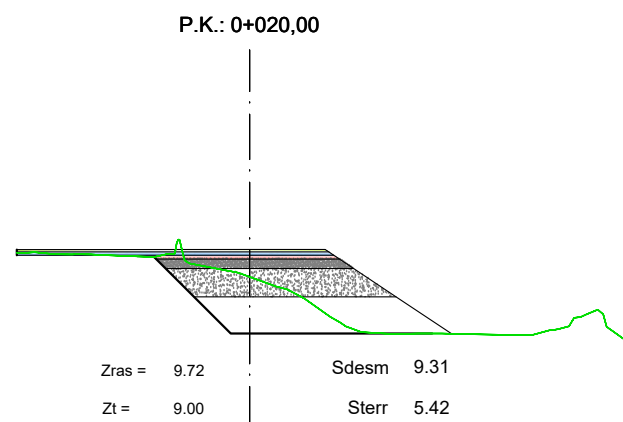
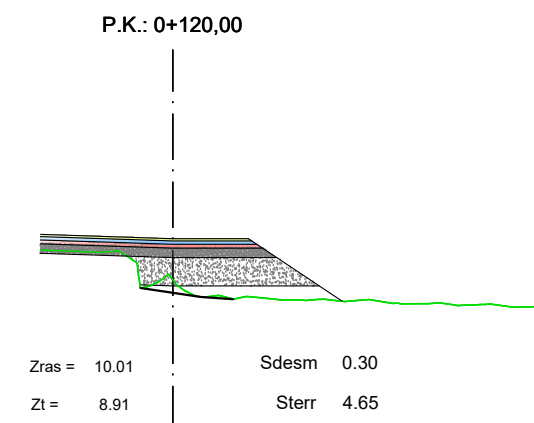
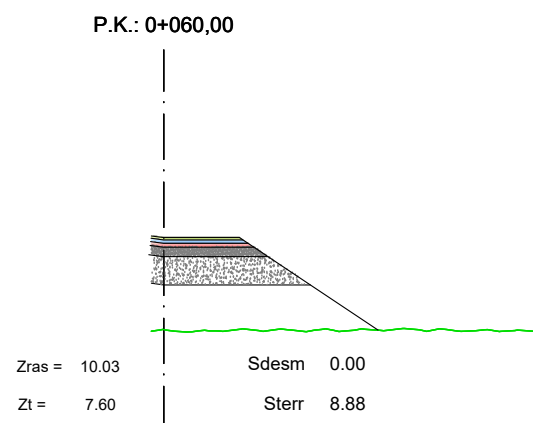
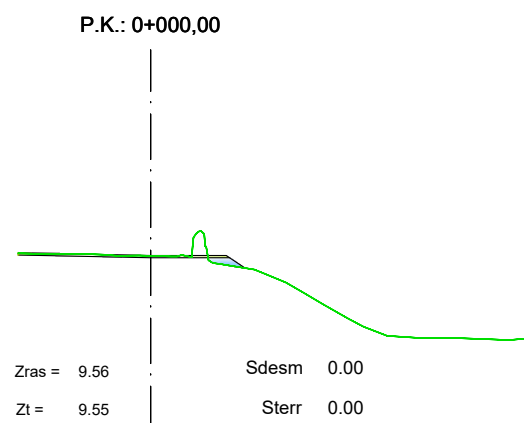

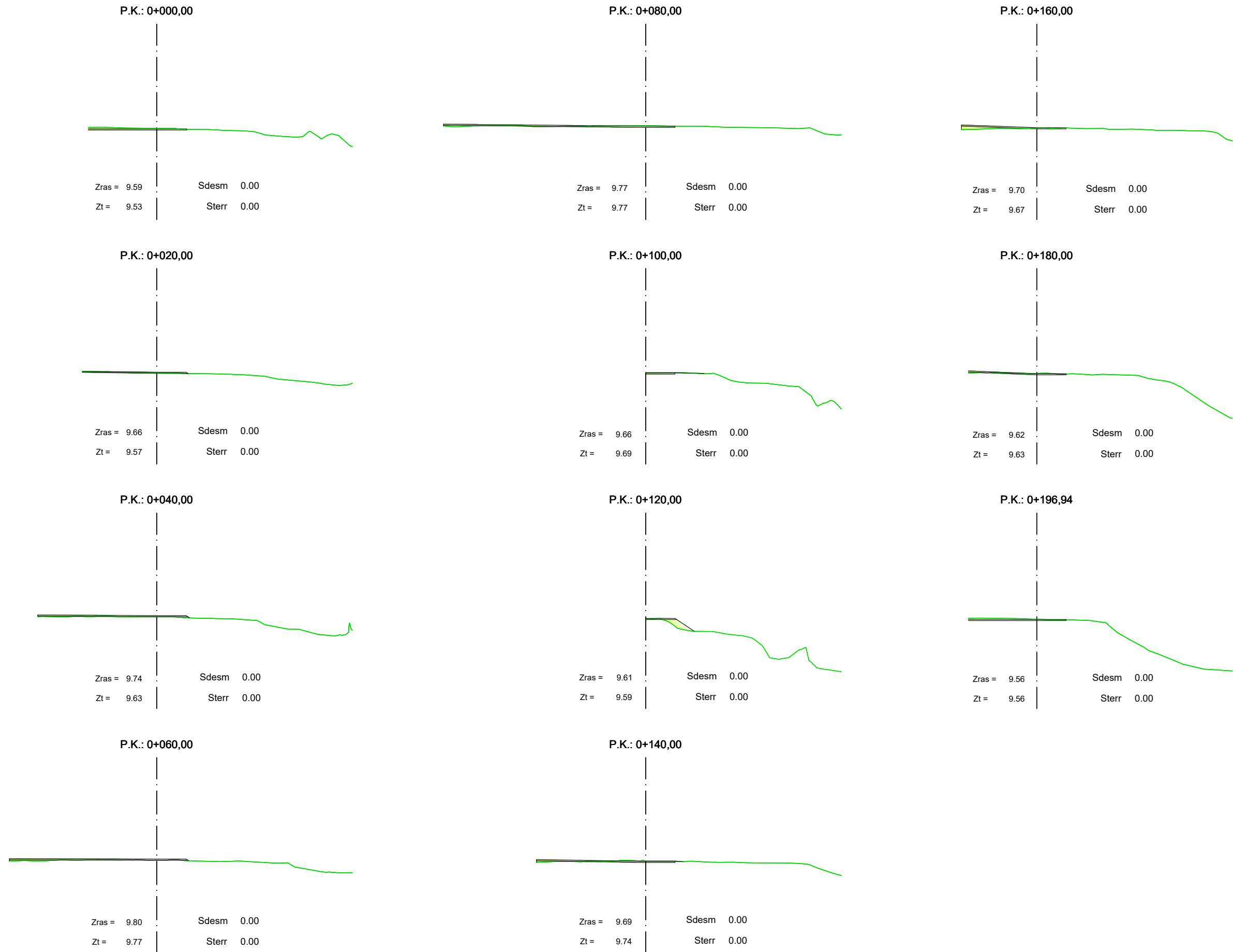

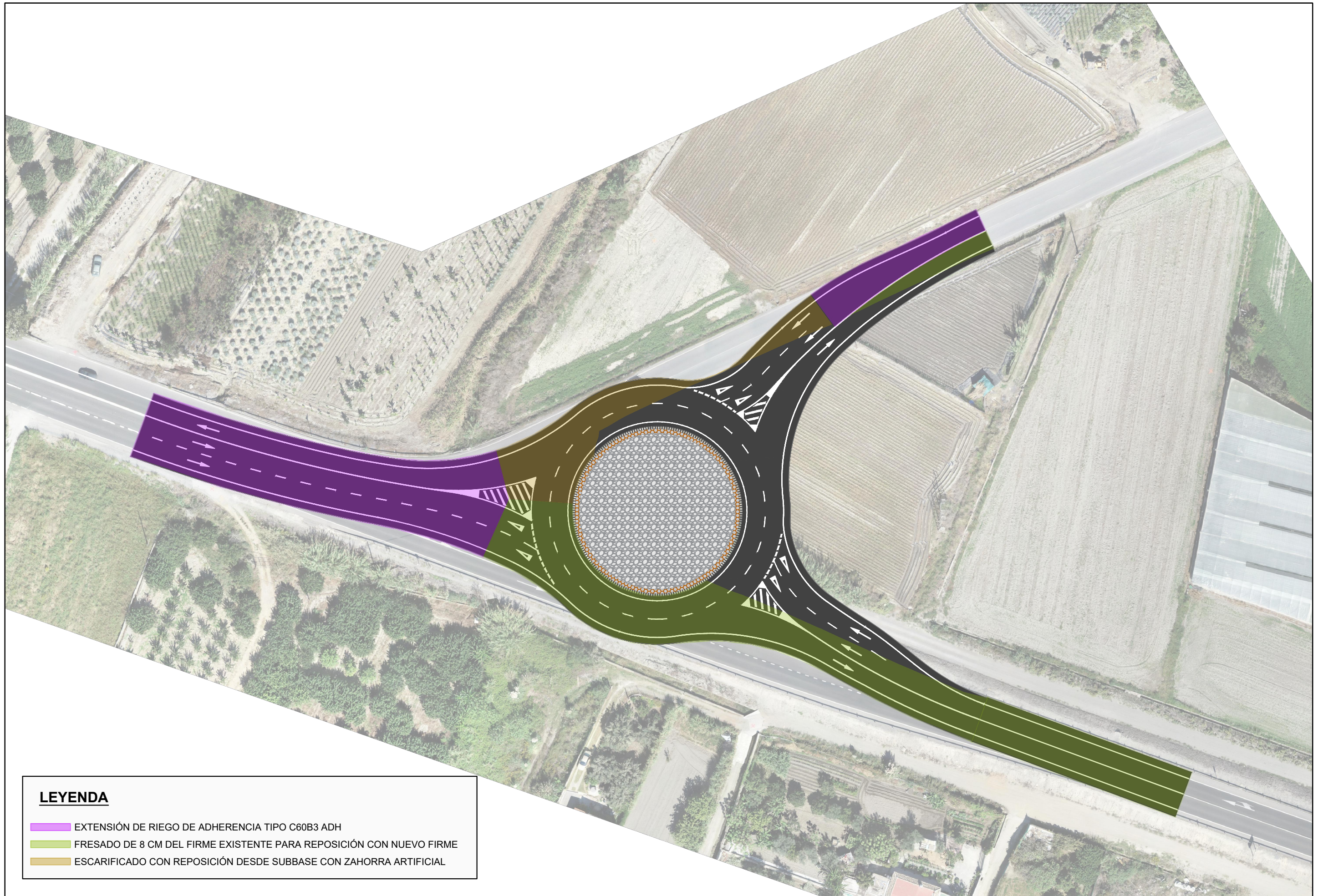

LEYENDA

- EXTENSIÓN DE RIEGO DE ADHERENCIA TIPO C60B3 ADH
- FRESADO DE 8 CM DEL FIRME EXISTENTE PARA REPOSICIÓN CON NUEVO FIRME
- ESCARIFICADO CON REPOSICIÓN DESDE SUBBASE CON ZAHORRA ARTIFICIAL

 <p>GOBIERNO DE ESPAÑA MINISTERIO DE TRANSPORTES, MOVILIDAD Y AGENDA URBANA</p>	<p>TÍTULO DEL PROYECTO:</p> <p>CONSTRUCCIÓN DE GLORIETA EN CARRETERA N-340, ACCESO OESTE MOTRIL, P.K. 330+800. PROVINCIA DE GRANADA</p>	<p>EMPRESA CONSULTORA:</p>  <p>Asitec <small>Ingeniería, Urbanismo y Medio Ambiente S.L.U.</small></p>	<p>AUTOR DEL PROYECTO:</p>  <p>JUAN MARTÍN FERNÁNDEZ COLEGIADO Nº: 13.958</p>	<p>DIRECTOR DEL CONTRATO:</p>  <p>DARÍO RODRÍGUEZ PEDROSA</p>	<p>FECHA:</p> <p>OCTUBRE 2020</p> <p>CLAVE:</p> <p>33-GR-4260</p>	<p>ESCALA:</p> <p>1:750</p>	<p>DESIGNACIÓN DEL PLANO:</p> <p>PREPARACIÓN DE SUPERFICIES Y DEMOLICIONES</p>	<p>Nº PLANO:</p> <p>8</p> <p>Hoja:</p> <p>1 de 1</p>
--	---	---	--	--	---	-----------------------------	--	--

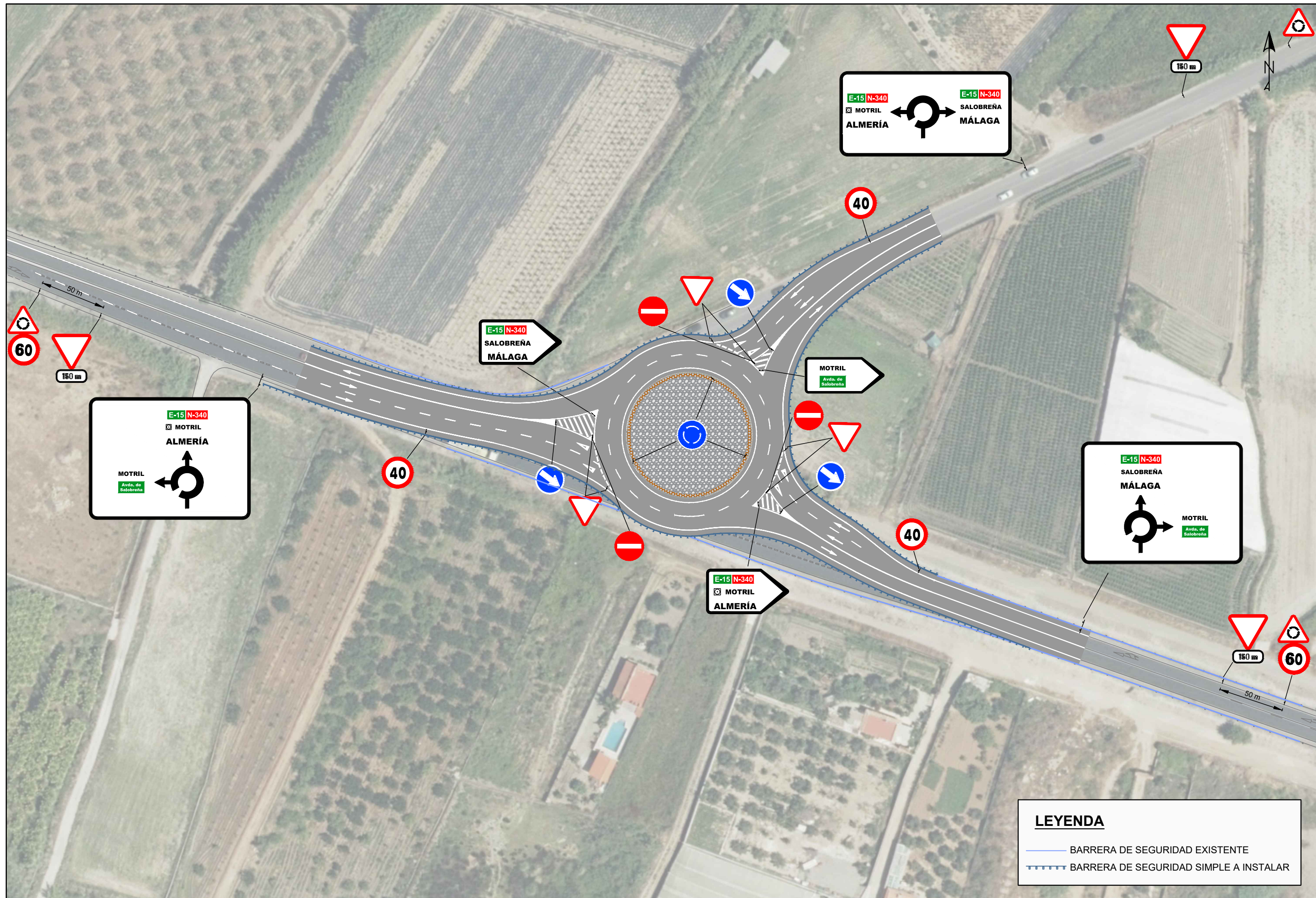

LEYENDA

	BARRERA DE SEGURIDAD EXISTENTE
	BARRERA DE SEGURIDAD SIMPLE A INSTALAR

MARCAS TRANSVERSALES

LÍNEA DE CEDA EL PASO

M-4.2



PARA BORDE DE CALZADA

M-2.6 VIAS CON $V_m \leq 100\text{Km/h}$.



PARA SEPARACIÓN DE CARRILES NORMALES

M-1.3 VIAS CON $V_m \leq 60\text{Km/h}$.

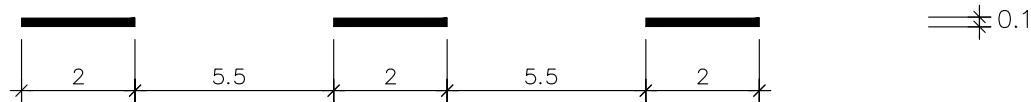

PARA SEPARACIÓN DE CARRILES NORMALES

M-2.2

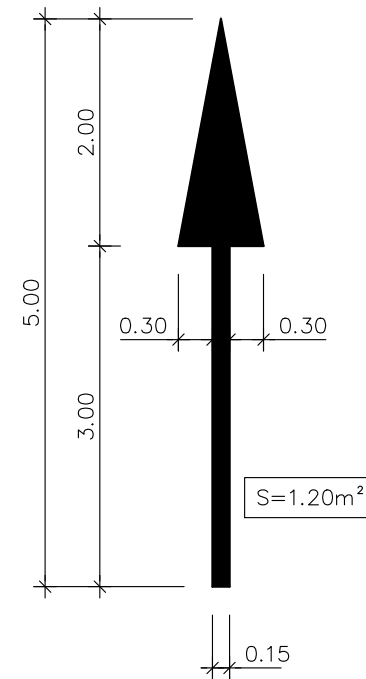

1. DE FRENTE

M-5-2 (FLECHAS DE DIRECCIÓN PARA $V_m < 60\text{Km/h}$.)

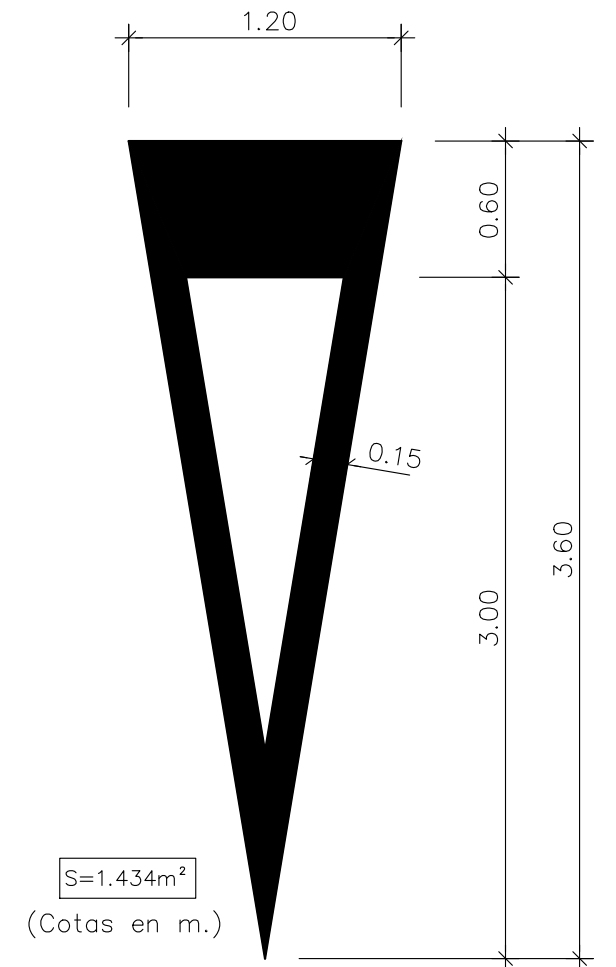

M-6.5 CEDA EL PASO

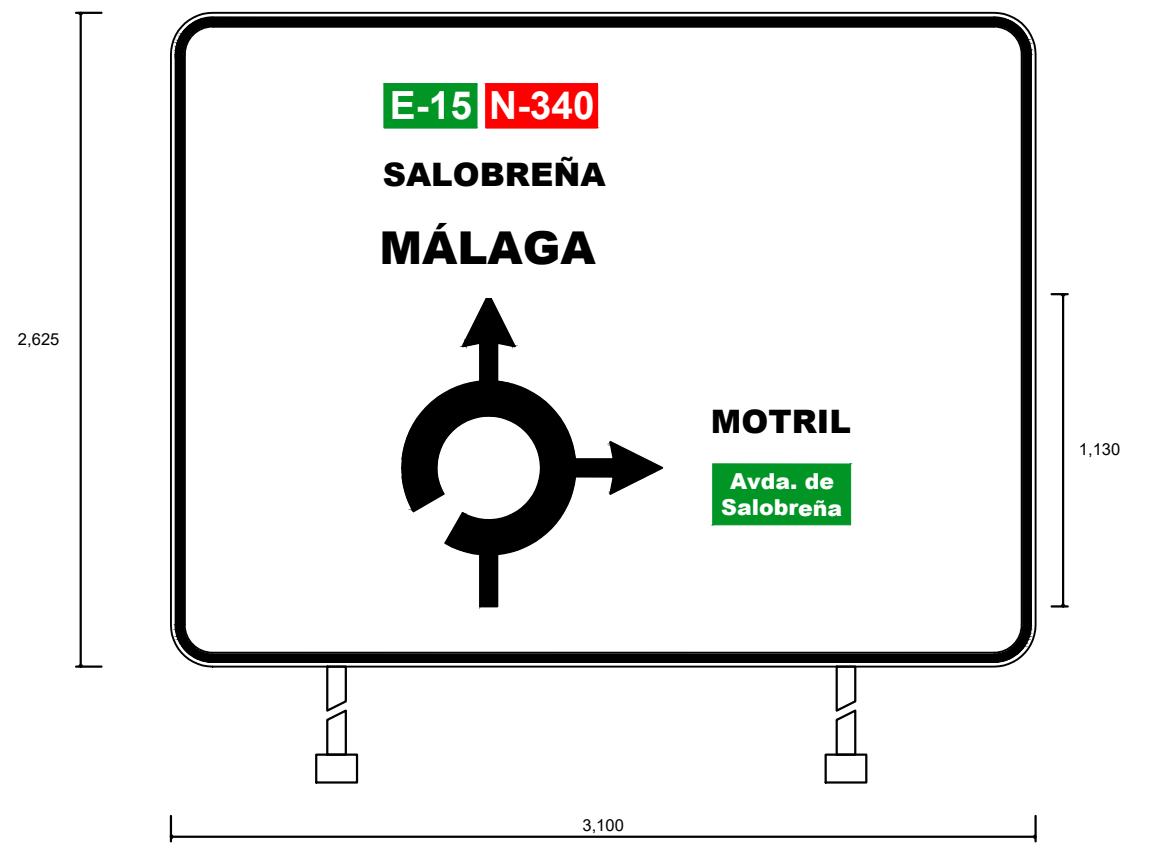
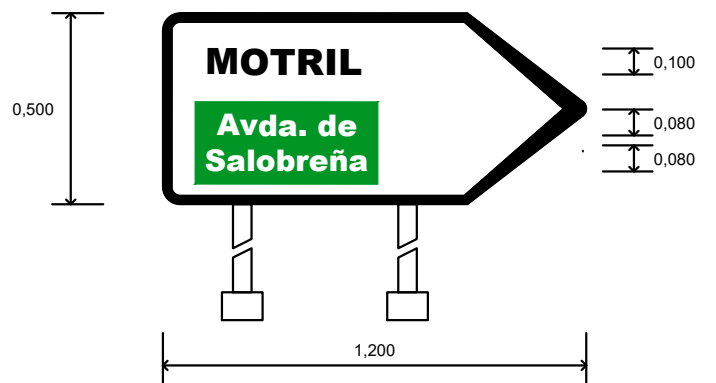
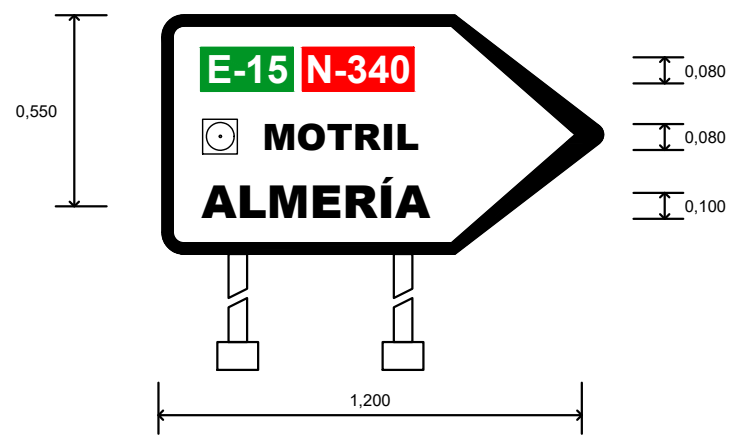
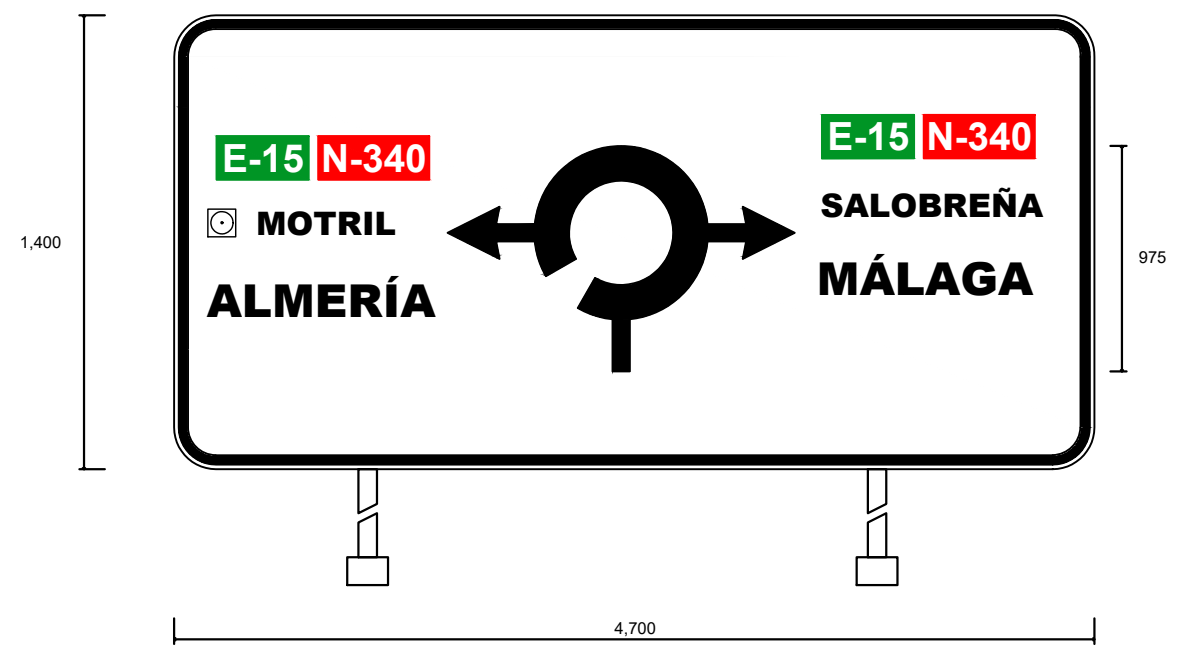
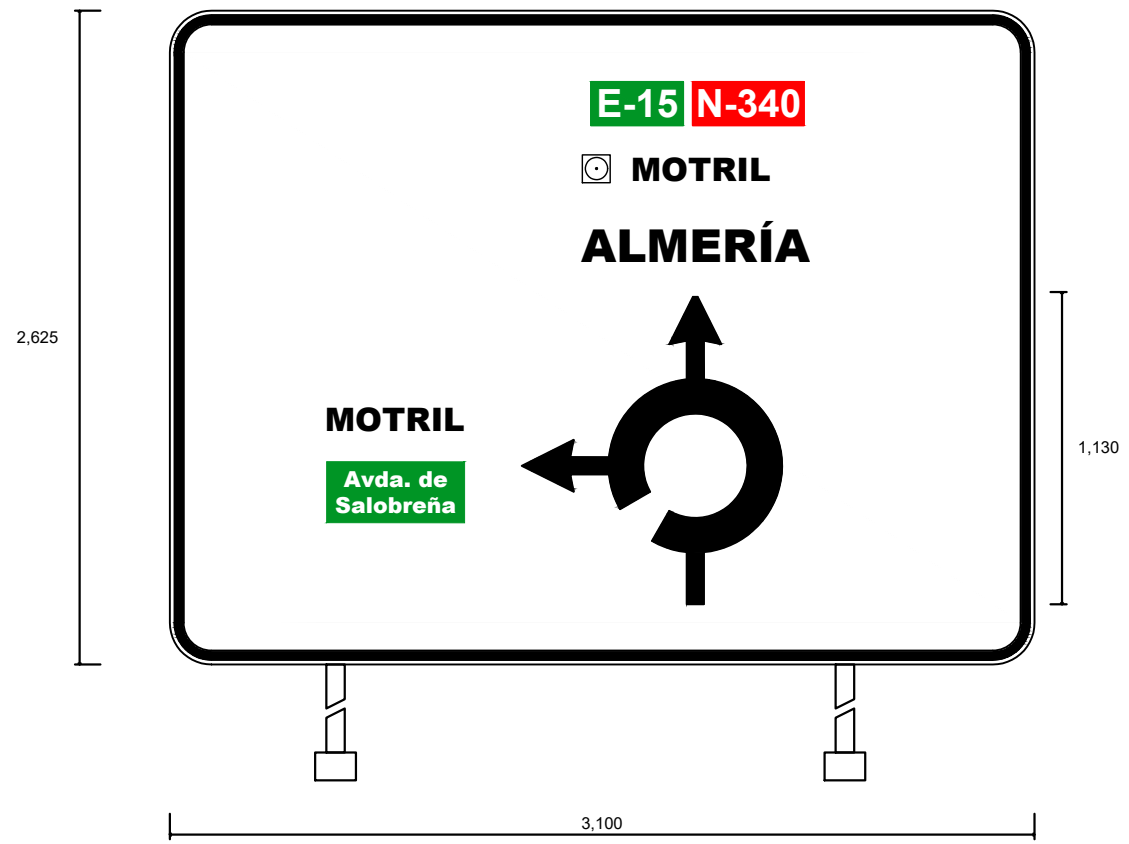

SEÑALIZACIÓN VERTICAL DIMENSIONES

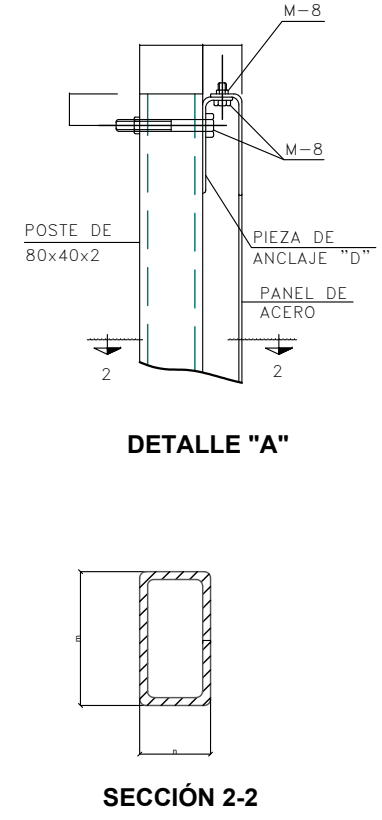
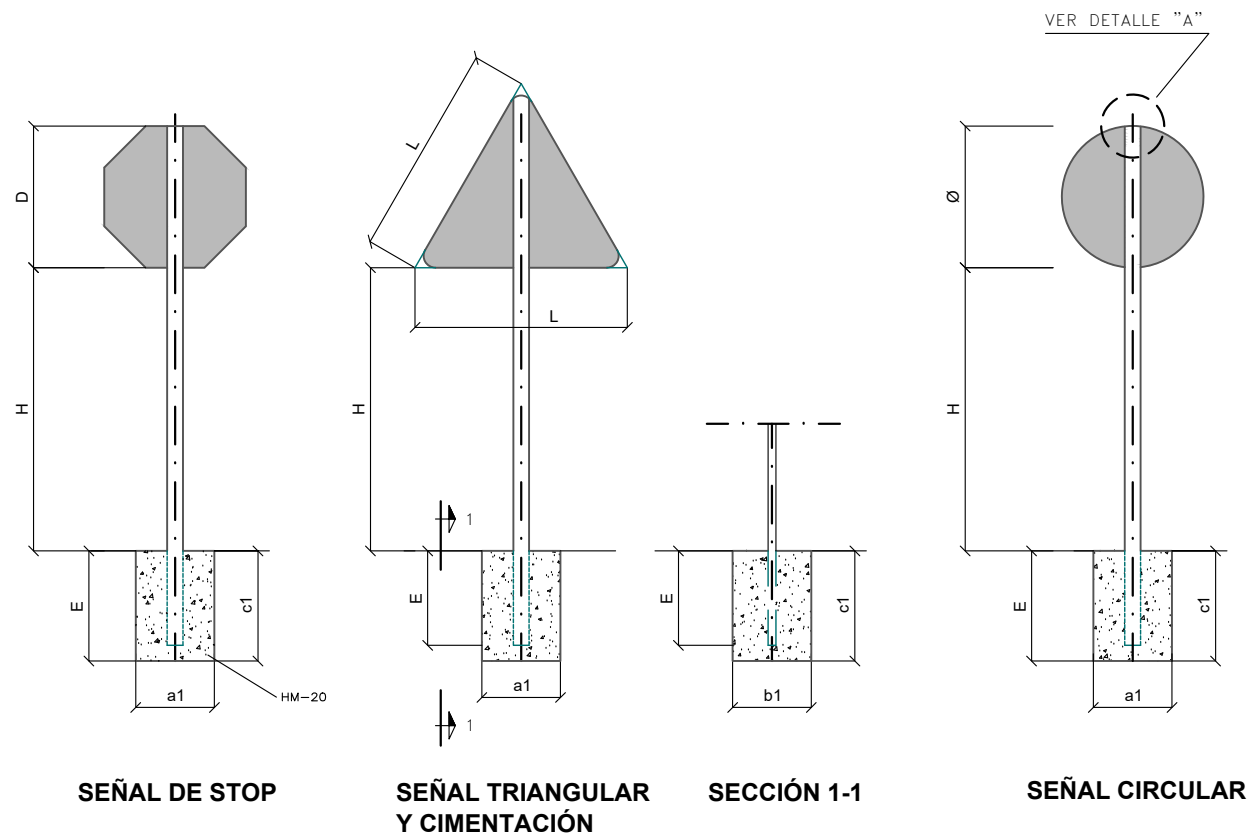

SOPORTES PARA SEÑALES DE CÓDIGO

TIPO	DIMENSIONES	SOPORTES			CIMENTOS				
		Nº	m	n	e	E	a1	b1	c1
SEÑALES TRIANGULARES	1750	1	120	60	3	650	850	500	800
	1350	1	100	50	3	550	700	400	700
SEÑALES CIRCULARES	1200	1	120	60	3	550	600	400	700
	900	1	100	50	3	550	600	400	700
SEÑALES CUADRADAS	1200x1200	1	100	80	3	750	750	500	900
	900x900	1	100	60	3	550	700	400	700
SEÑALES RECTANGULARES	400x400	1	80	40	2	450	500	400	600
	1800x1200	2	100	80	3	750	1200	600	900
SEÑALES MIXTAS	1350x900	1	120	60	3	650	800	500	800
	Rect. L = 1750 Circ. Ø=1200	1	120	60	3	850	600	400	1000
SEÑALES MIXTAS	Rect. L = 1350 Circ. Ø=900	1	120	60	3	550	700	400	700
	Apotema: 900	1	100	50	3	550	600	400	700
OCTOGONALES	Apotema: 600	1	80	40	2	450	400	400	600

DIMENSIONES SEÑALES DE CÓDIGO

TIPO DE VÍA	H	L	Ø	D	L1	L2
Autovía	2000	175	1200		1200	1800
Carretera convencional con arcén	1800	135	900	900	900	1350
Caminos	1500	900	600	600		

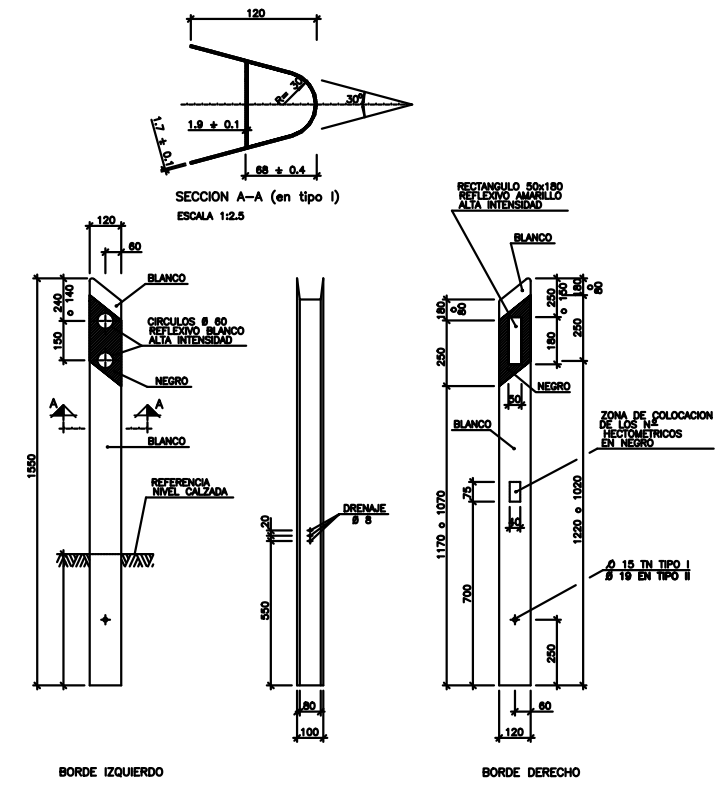
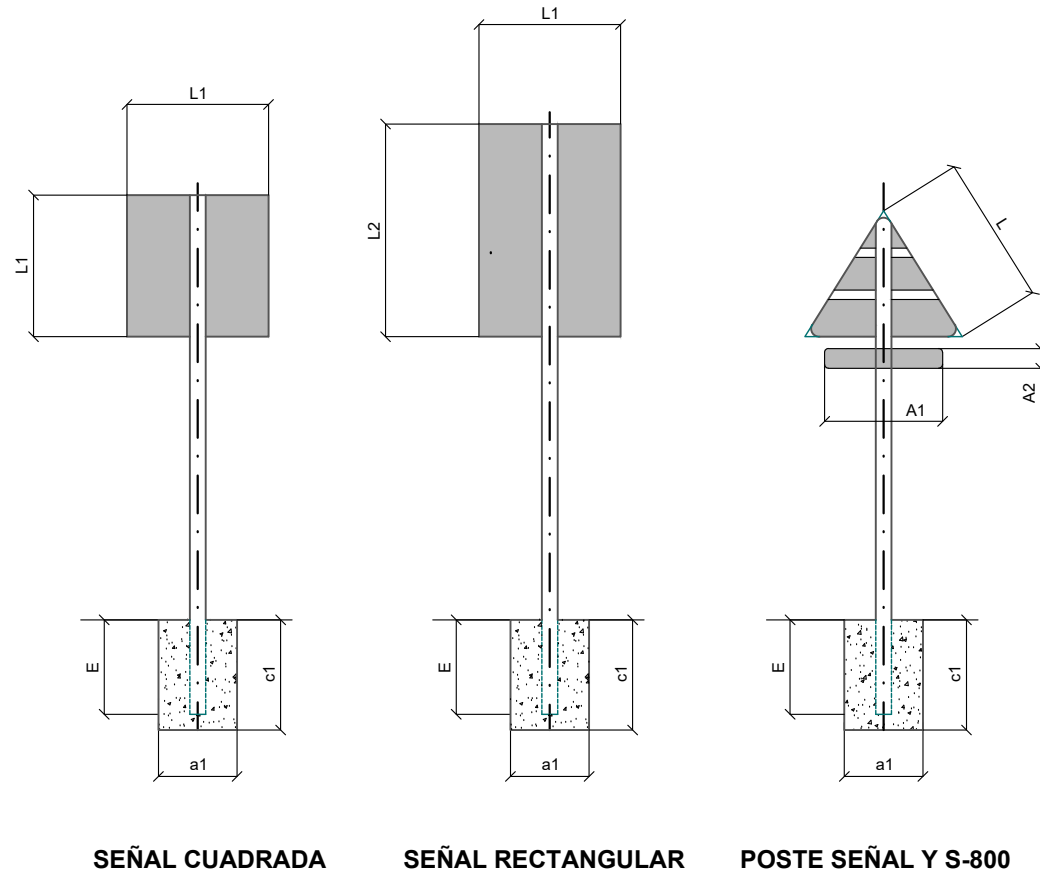

HITO DE ARISTA: TIPO I: EN CALZADAS DE DOS SENTIDOS
TIPO II: EN CALZADAS SEPARADAS
(cotas en m.m.)

ESQUEMA DE MONTAJE

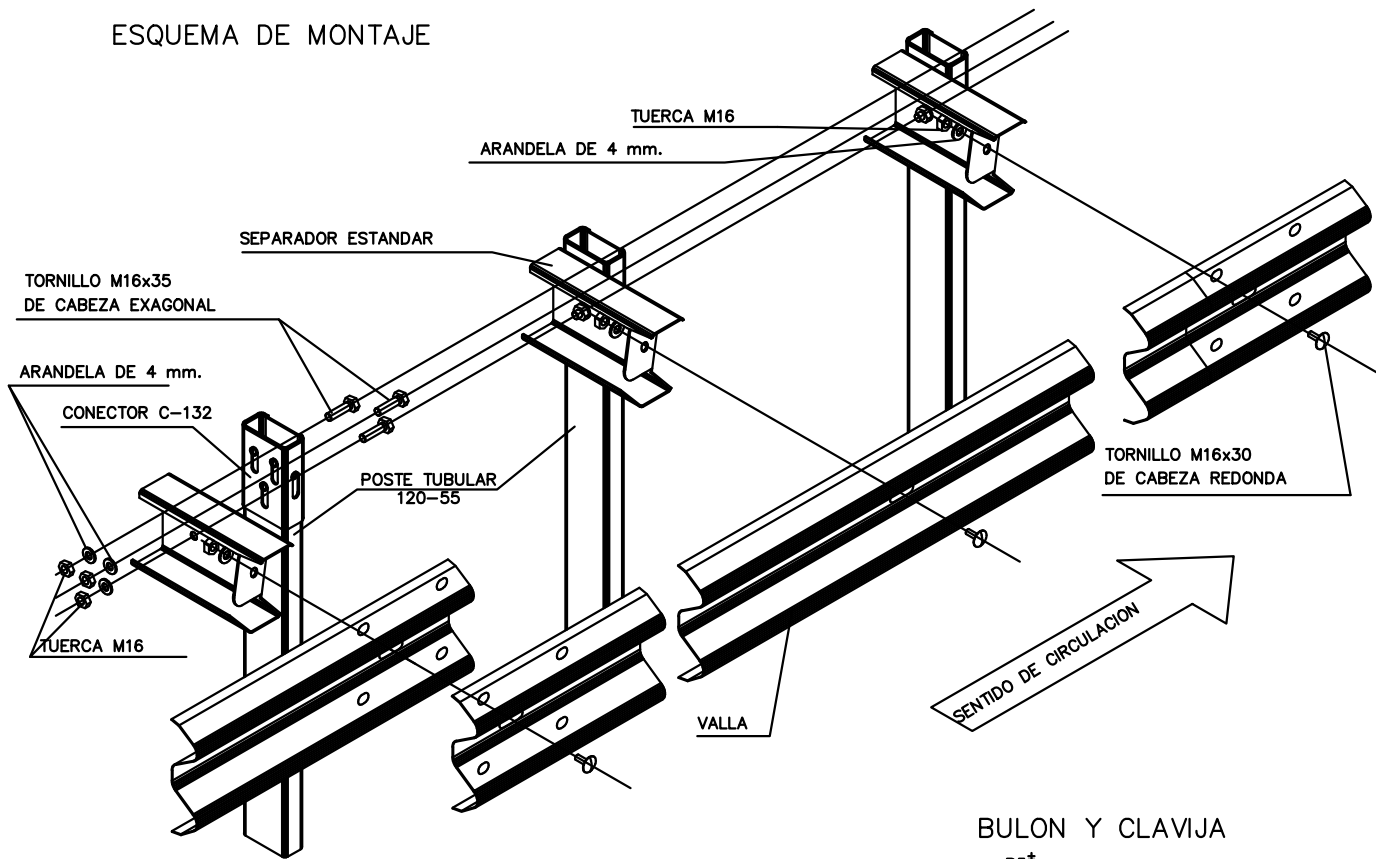

PERFIL BARRERA METALICA

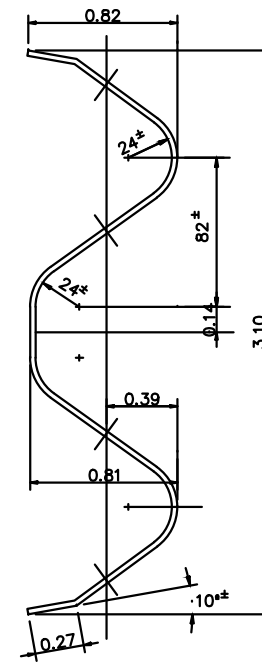

SEPARADOR VALLA DESMONTABLE
cotas en mm.

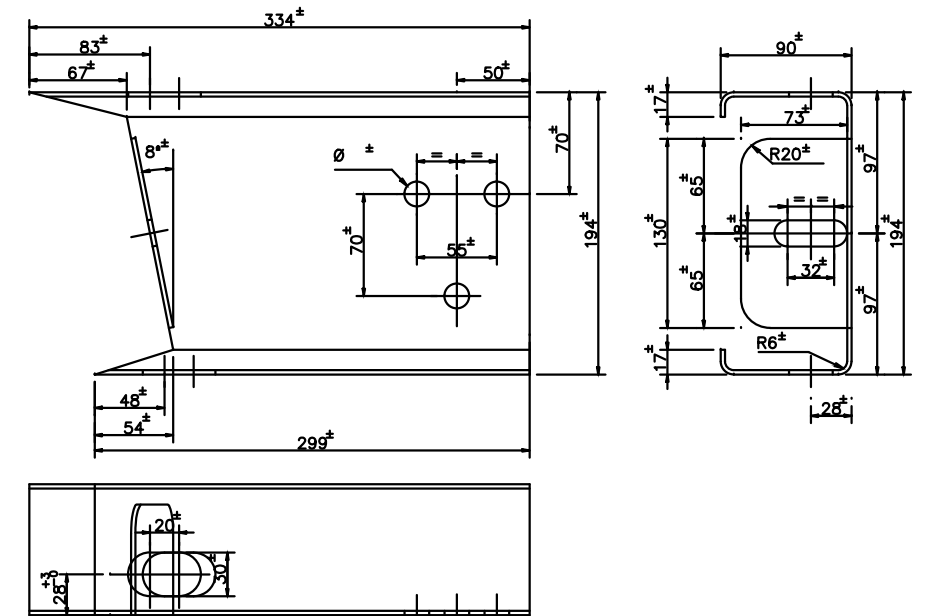

SEPARADOR VALLA SIMPLE
cotas en mm.

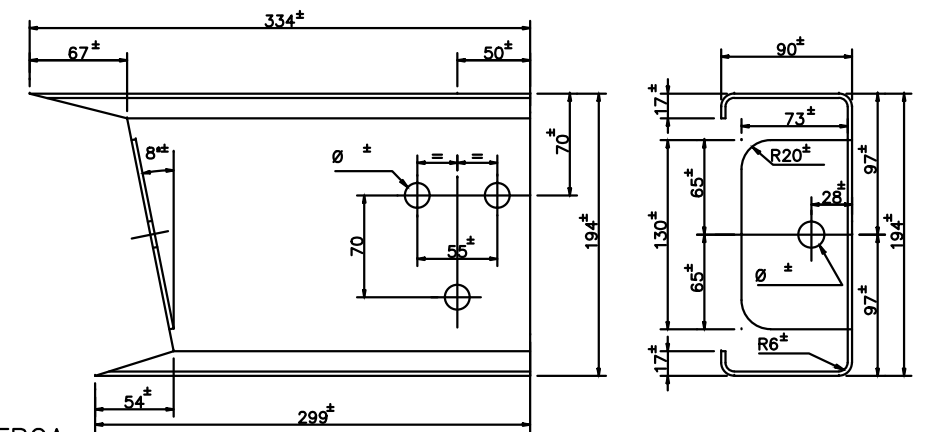

VALLA RECTA
cotas en mm.

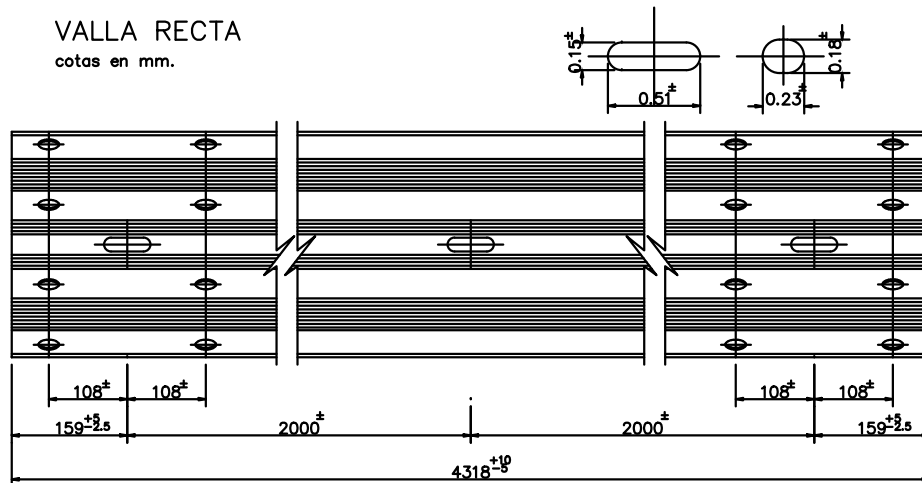

VALLA RECTA DESMONTABLE

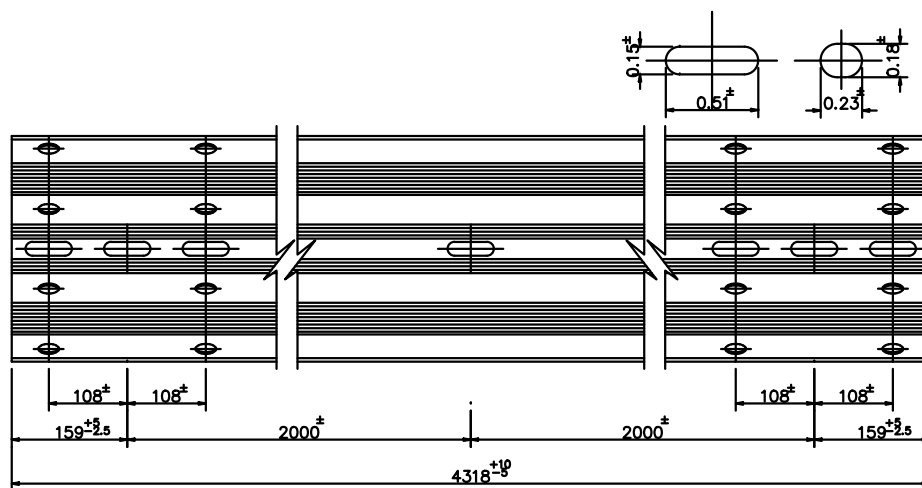

BULON Y CLAVIJA

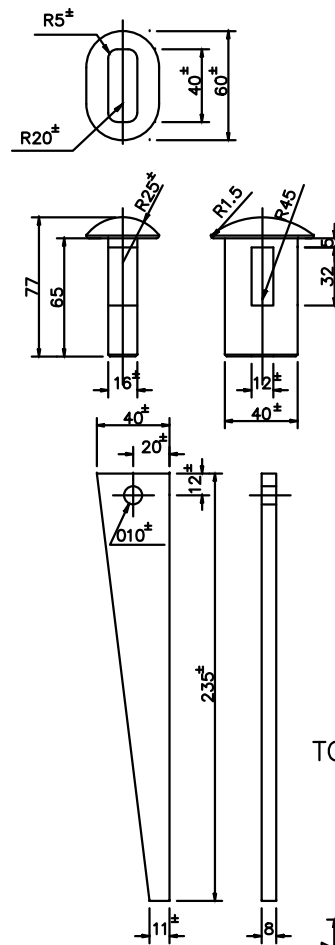

TORNILLO M16 ARANDELA Y TUERCA

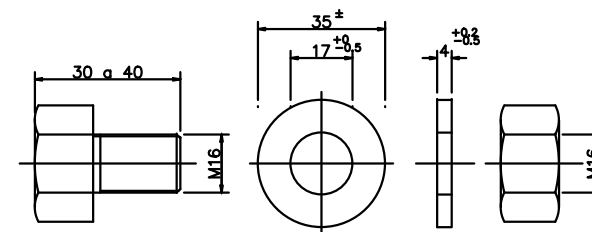

TORNILLO M16 CABEZA REDONDA ARANDELA Y TUERCA

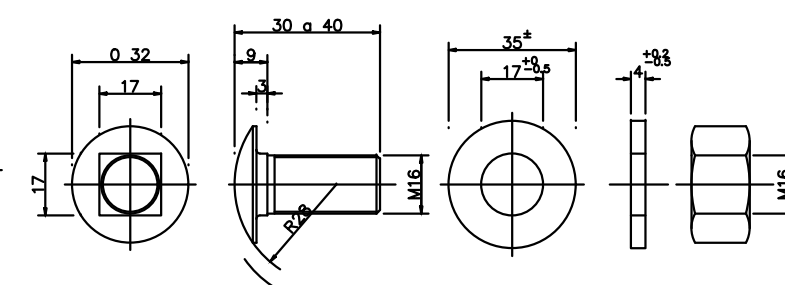

SEPARADOR VALLA SIMPLE
cotas en mm.

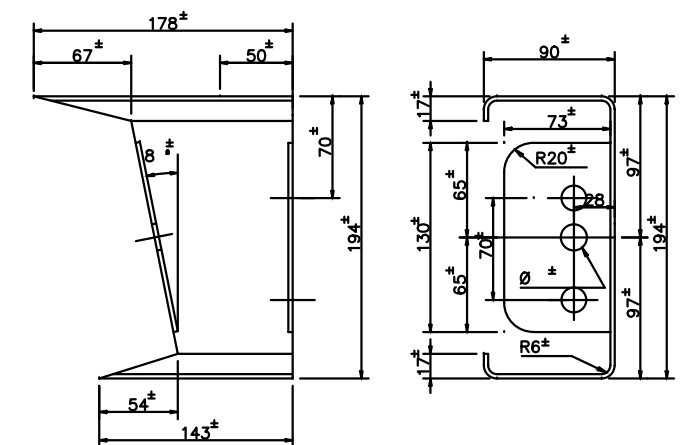

ESQUEMA DE IMPLANTACION EN CALZADA DE DOS SENTIDOS

ALZADO

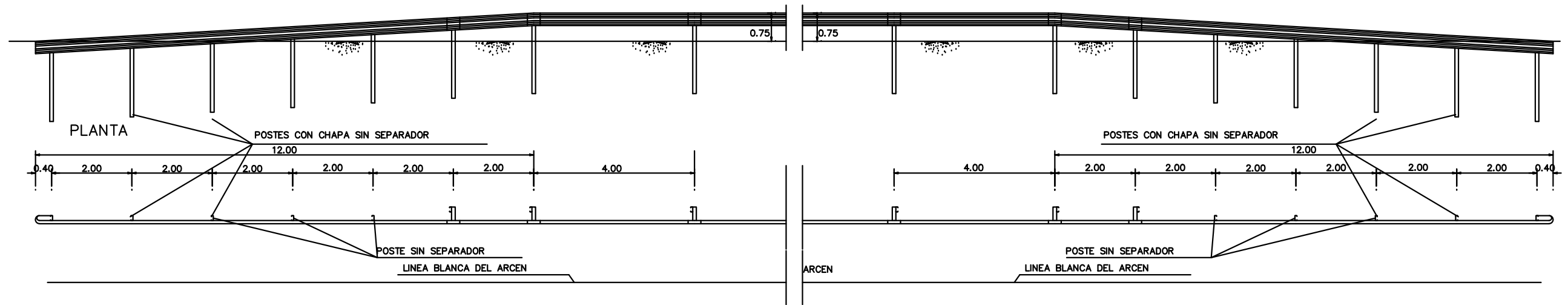

ESQUEMA DE EMPOTRAMIENTO EN DESMORTE

ALZADO

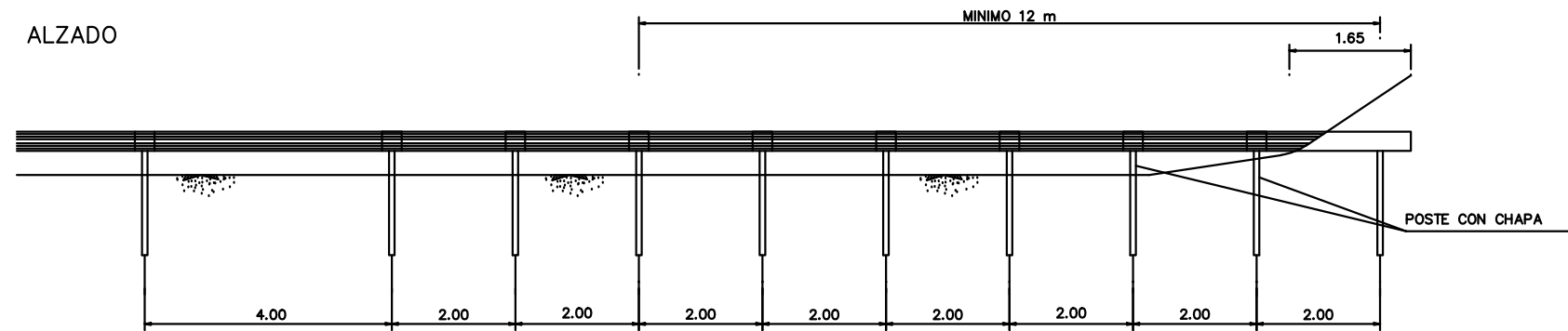

PLANTA

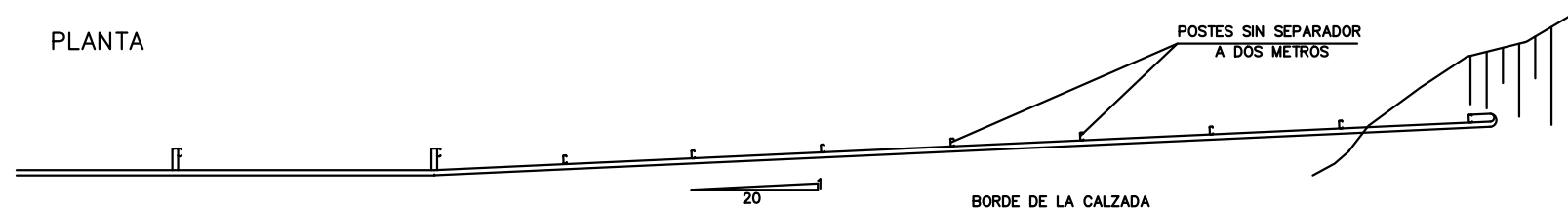

PROCEDIMIENTO NORMAL DE HINCA DEL POSTE EN EL TERRENO

LA LONGITUD DEL POSTE PUEDE REDUCIRSE A 1500 EN TERRENOS DUROS Y COMPACTOS SEGUN APARTADO 5.1.5.1 O.C.

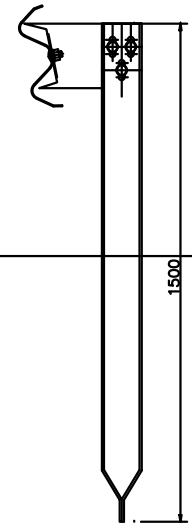

PIEZA ANGULAR

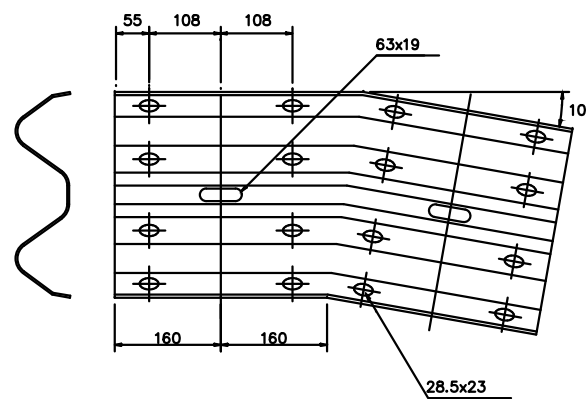

PLETINA DE FIJACION

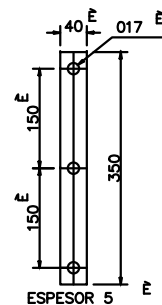

CONECTOR C-132

ESCALA 1/25 cotas en mm.

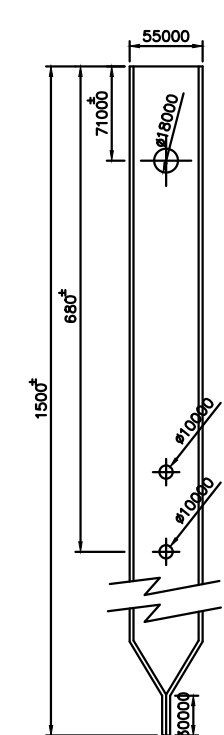
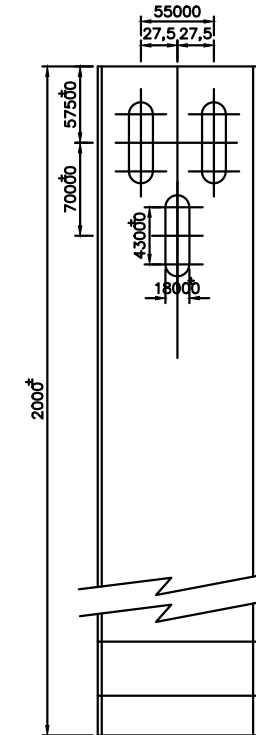
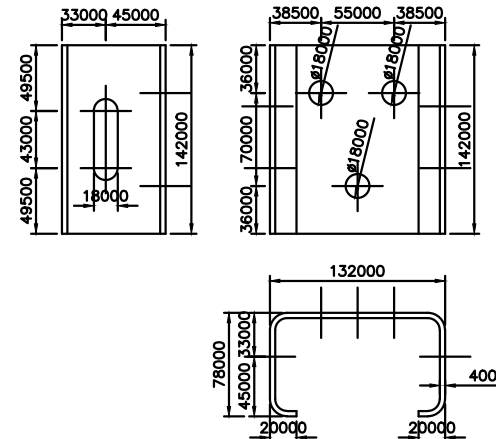



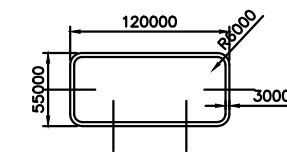

POSTE TUBULAR 120 - 55



cotas en mm.

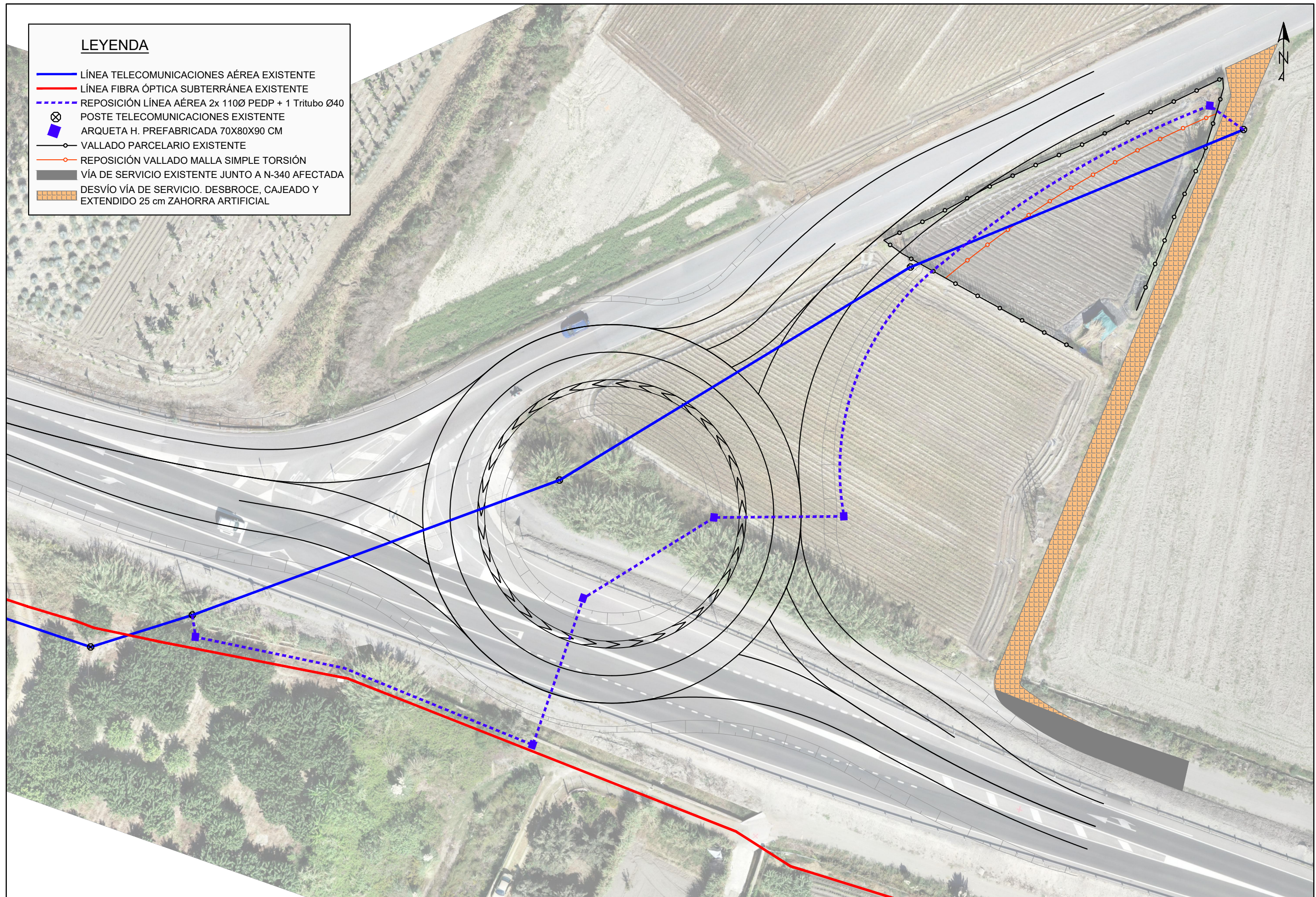

LEYENDA

- LÍNEA TELECOMUNICACIONES AÉREA EXISTENTE
- LÍNEA FIBRA ÓPTICA SUBTERRÁNEA EXISTENTE
- - - REPOSICIÓN LÍNEA AÉREA 2x 110Ø PEDP + 1 Tritubo Ø40
-  POSTE TELECOMUNICACIONES EXISTENTE
-  ARQUETA H. PREFABRICADA 70X80X90 CM
-  VALLADO PARCELARIO EXISTENTE
- REPOSICIÓN VALLADO MALLA SIMPLE TORSIÓN
-  VÍA DE SERVICIO EXISTENTE JUNTO A N-340 AFECTADA
-  DESVÍO VÍA DE SERVICIO. DESBROCE, CAJEADO Y EXTENDIDO 25 cm ZAHORRA ARTIFICIAL



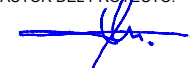
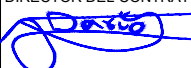



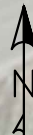

 <p>GOBIERNO DE ESPAÑA MINISTERIO DE TRANSPORTES, MOVILIDAD Y AGENDA URBANA</p>	<p>TÍTULO DEL PROYECTO: CONSTRUCCIÓN DE GLORIETA EN CARRETERA N-340, ACCESO OESTE MOTRIL, P.K. 330+800. PROVINCIA DE GRANADA</p>	<p>EMPRESA CONSULTORA:  Ingeniería, Urbanismo y Medio Ambiente S.L.P.</p>	<p>AUTOR DEL PROYECTO:  JUAN MARTÍN FERNÁNDEZ COLEGIADO Nº: 13.958</p>	<p>DIRECTOR DEL CONTRATO:  DARÍO RODRÍGUEZ PEDROSA</p>	<p>FECHA: OCTUBRE 2020</p>	<p>ESCALA: 1:500</p>	<p>DESIGNACIÓN DEL PLANO: REPOSICIONES PLANTA</p>	<p>Nº PLANO: 10</p>
					<p>CLAVE: 33-GR-4260</p>			<p>Hoja: 1 de 2</p>





LEYENDA

-  Canalización Alumbrado Público 2Ø110 mm
-  Arqueta Alumbrado Público 40x40x60 cm
-  Columna de 9 metros con luminaria (tipo Town o similar), lámpara 15 LED 92W y arqueta de alumbrado junto a la base
-  Columna de 18 metros de altura con 8 proyectores (tipo Visio o similar), 30 LED 259 W y arqueta de alumbrado junto a la base

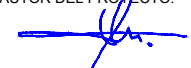
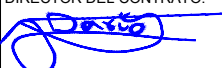
 GOBIERNO DE ESPAÑA MINISTERIO DE TRANSPORTES, MOVILIDAD Y AGENDA URBANA	TÍTULO DEL PROYECTO: CONSTRUCCIÓN DE GLORIETA EN CARRETERA N-340, ACCESO OESTE MOTRIL, P.K. 330+800. PROVINCIA DE GRANADA	EMPRESA CONSULTORA:  Ingeniería, Urbanismo y Medio Ambiente S.L.P.	AUTOR DEL PROYECTO:  JUAN MARTÍN FERNÁNDEZ COLEGIADO Nº: 13.958	DIRECTOR DEL CONTRATO:  DARIÓ RODRÍGUEZ PEDROSA	FECHA: OCTUBRE 2020	ESCALA: 1:750	DESIGNACIÓN DEL PLANO: ILUMINACIÓN PLANTA	Nº PLANO: 11.2
					CLAVE: 33-GR-4260			Hoja: 1 de 1

